

FILTON

ROTARY UNION
technical manual

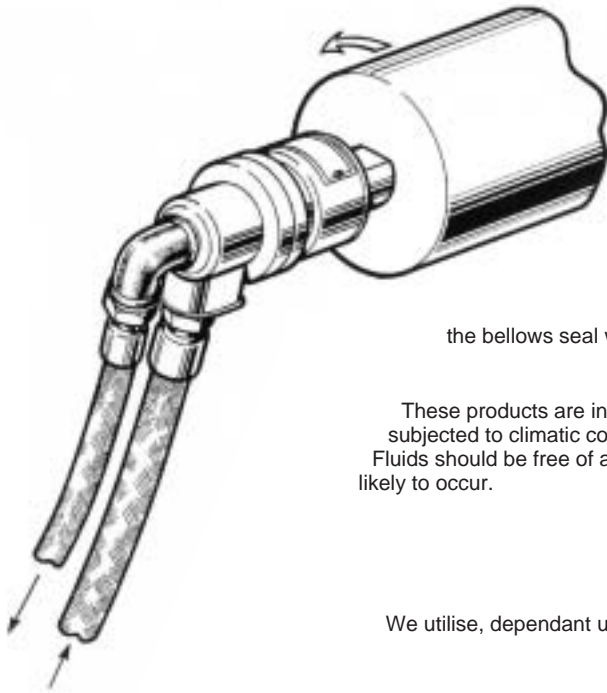



A Rotary Union is a device which can be connected to a rotating shaft and allow the leakproof transfer of fluids to and from the stationary services.

The vital components of Rotary unions are the rotary seals and the bearing support systems. For the majority of applications the FILTON BELLOWS SEAL is the most efficient. If pressure and/or speed exceed the capability of

the bellows seal we can provide a FILTON MECHANICAL SEAL.

Important

These products are intended for use on a factory environment. Contact us if the installation is subjected to climatic conditions.

Fluids should be free of abrasive particles and water systems should be treated if "scaling" is likely to occur.

Rotary Seals

We utilise, dependant upon the application, a bellows seal or a mechanical seal:

Filton Bellows Seals

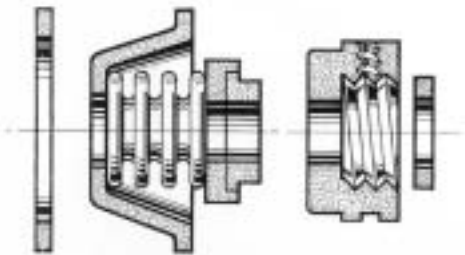

The Filton Bellows Seal has advantages over the mechanical seal on steam, hot water and heat transfer fluids. This seal does not contain any elastomeric components and is therefore satisfactory from sub-zero temperatures up to 300°C.

Filton Mechanical Seals

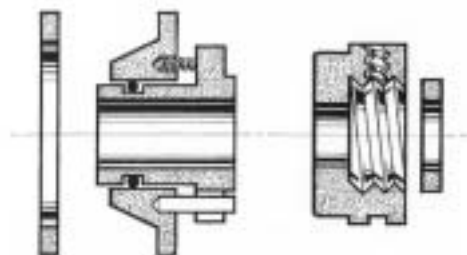

The Filton Mechanical Seal is utilised for higher pressures, such as hydraulic systems and the higher shaft speeds used, for example, on machine tools. The springs for the mechanical seal are out of the fluid flow area.

The one common factor with both Filton Bellows Seals and Mechanical Seals is the quality of the seal contact faces. These are lapped to a high accuracy and checked optically to ensure the correct flatness is obtained.

Bearings

The range of Rotary Unions we offer include units with standard ball bearings, angular contact ball bearings and carbon journal and thrust bearings.

The ball bearings used generally have an upper temperature limit of 180°C, (this can be exceeded with special bearings and lubrication), whereas carbon bearings can be used up to 300°C. Carbon bearings have speed limitations which can be far exceeded by ball bearings.

Who are Filton Limited?

Filton Limited is a Private Limited Company which celebrated its 60th Anniversary in 2002. The Company was founded by Mr William Murray, to manufacture conventional leather oil seals for rotary shafts, but is now universally known as one of the world's leading manufacturers of Rotary Unions, various types of which are described in the following pages. The main interest of the Company is still with rotary seals but using state of the art designs and when required, sophisticated seal face materials which enable us to undertake and solve complex sealing problems. Multi-port Rotary Unions are now common-place, and if a suitable design is not already available our design team is at your disposal to consider the specification needed. **Quality is Paramount.** All components are rigorously inspected during manufacture and every Rotary Union is pressure tested before despatch to ensure satisfactory performance when installed in accordance with our recommendations.

SEE PAGE 29 FOR CONTENTS AND INDEX

Throughout this technical manual the designation for pipe threads is:-

'G' - Parallel pipe thread to BS.2779 & ISO.228/1 (formerly designated B.S.P. - Parallel)

'R' - Tapered pipe thread to BS.21 & ISO.7/1 (formerly designated B.S.P. - Taper)

Single flow - type B.E.

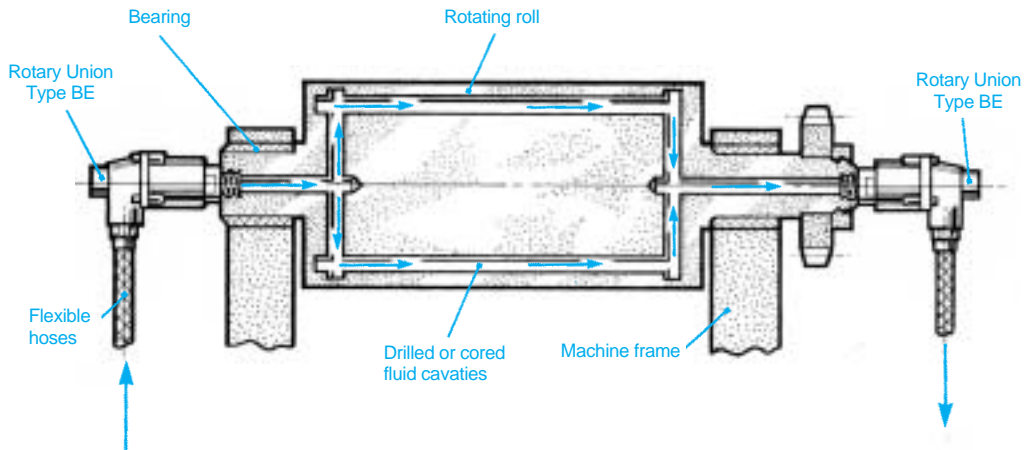

FILTON ROTARY UNIONS type B.E. shown on a drilled roll typical of a plastics calendar.

Fluids are generally water, oil or heat transfer fluid.

Double flow - type S.T. (stationary centre tube)

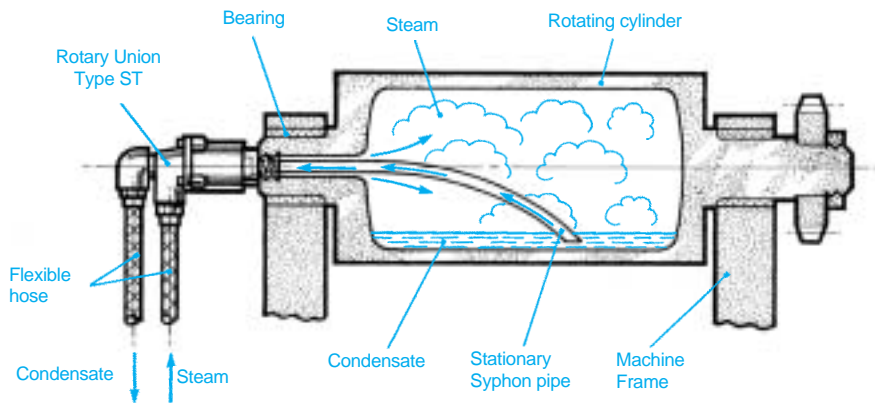

FILTON ROTARY UNION type S.T. shown on a steam heated cylinder typical of a paper dryer.

Double flow - type R.S. (rotary centre tube)

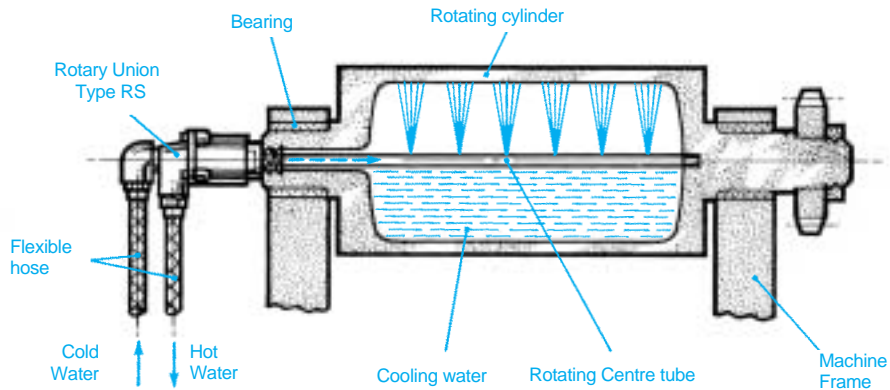

FILTON ROTARY UNION type R.S. shown on a water cooled roll typical of a rubber mill.

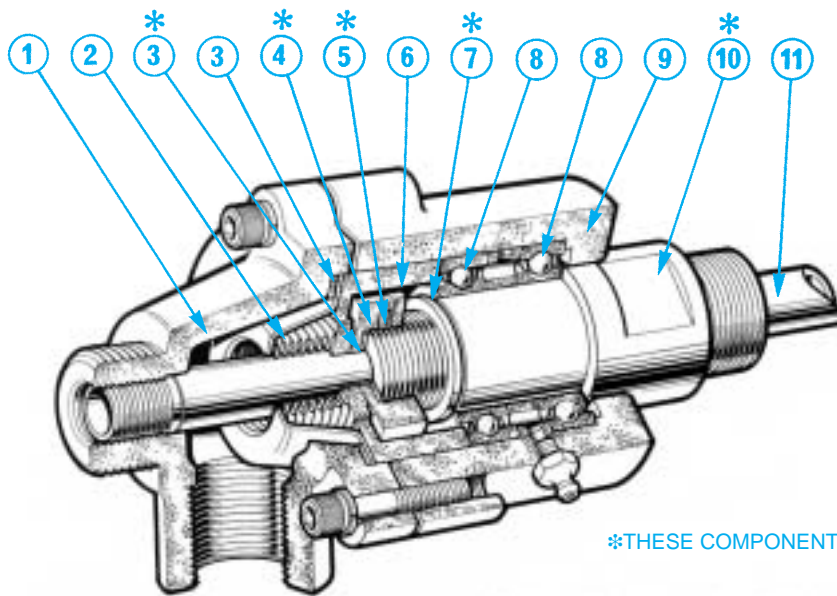

Rotary (R.E.) Union type S.T.

1. Adaptor, high quality cast iron.
2. Bellows sub-assembly, brazed stainless steel.
3. Gaskets.
4. Seal ring sub-assembly, steel/carbon.
5. Locking screw, h.t. steel.
6. Spacer.
7. Circlip.
8. Ball bearings.
9. Body high quality cast iron.
10. Rotary spindle, steel.
11. Centre tube, if ordered, to customers specification.

※THESE COMPONENTS ROTATE WITH THE MACHINE SHAFT

The Rotary (R.E.) Union is a self contained, self supporting rotary seal for the leak proof transfer of fluids (such as steam, water, air or oil) to and from rotating machine shafts.

The type of Rotary Seal fitted to the Rotary (R.E.) Union is a "FILTON BELLOWS SEAL" containing a flexible stainless steel bellows which is self adjusting, eliminating the maintenance common with conventional packed glands. Rotary sealing is created by relative rotation between extremely flat sealing faces (items 2 and 4) held in contact by the spring characteristic of the bellows with an additional sealing force created by pressure of the fluid passing through the Rotary (R.E.) Union. The bearings fitted to the Rotary (R.E.) Union are standard ball bearings which are given their initial lubrication before despatch.

There are 3 variations of the stationary Adaptor end, diagrams on page 5 and described below:-

TYPE R.E./B.E.

This Rotary (R.E.) Union is a single flow unit and is suitable for transferring fluid in to or out of rotating machines. A typical application for this type is shown in page 3.

TYPE R.E./S.T.

This Rotary (R.E.) Union is fitted with an Adaptor suitable for double flow with a stationary centre tube. This gives flow areas through the centre tube and annulus. Centre tubes are only provided if ordered. The centre tube is fixed to the Rotary (R.E.) Union end by means of a screw thread shown as dimension 'O'. Flow can pass in through the centre tube and return through the annulus or be reversed. For steam applications, a typical example of which is shown on page 3, the centre tube is curved to reach the condensate in the bottom of the cylinder. At times the roll neck diameter to length ratio prevents a curved tube being used, in such cases we can provide a Syphon Elbow details of which are on page 20.

TYPE R.E./R.S.

The Adaptor fitted to this Rotary (R.E.) Union is suitable for a rotating centre tube, which must be located and driven by the machine. Centre tubes are only provided if ordered. For the type R.E./R.S. the centre tube rotates in a bush. The centre tube "sealing" system allows a slight internal leakage between the supply and return lines. If these fluids must not mix then an alternative design can be provided, please ask our Technical Department. Flow can pass in through the centre tube with the return through the annulus or be reversed. A typical application is shown on page 3.

Operational Guidelines (For other conditions contact Filton Limited)

FLUIDS

Water, steam, mineral oils, heat transfer fluids and compressed air (lubricated). All fluids should be clean and free from abrasive particles.

PRESSURE

17 bar maximum.

VACUUM

740 mm Hg. maximum (specify vacuum and we will test for this).

TEMPERATURE

-20° to 180°C (with suitable effective lubrication 200°C).

SPEED

1000 r.p.m. maximum up to 25(1") r.p.m. and 800 r.p.m. above.

* Flow in cubic metres/hour at a velocity of 3 metres/second. Applies also to other liquids

† Flow in kilograms/hour at a velocity of 30 metres/second and a pressure of 6 bar.

★ Flow in cubic metres/hour free air at a velocity of 15 metres/second and a pressure bar of 6 bar.

FLOW CAPACITY

Nominal Size	Type	Water*		Steam†	Air★
		m ³ /h	l/min		
8 (1/4")	{ B.E.	0.3	5	11	11
	{ S.T. & R.S.	0.05	0.8	3.4	2
10 (3/8")	{ B.E.	0.8	13.3	31	29
	{ S.T. & R.S.	0.1	1.7	16	4
15 (1/2")	{ B.E.	1.7	28.3	61	58
	{ S.T. & R.S.	0.3	5	27	10
20 (3/4")	{ B.E.	2.7	45	101	96
	{ S.T. & R.S.	0.6	10	41	22
25 (1")	{ B.E.	4.1	68.3	151	144
	{ S.T. & R.S.	1.8	30	56	44
32 (1 1/4")	{ B.E.	7.6	127	280	267
	{ S.T. & R.S.	2.1	35	133	74

IT IS NOT ADVISABLE TO COMBINE MAXIMUMS

ROTARY (R.E.) UNIONS



For single flow type R.E./B.E.

Nominal Size	Part No.	
8 (1/4")	14642	R or L
10 (3/8")	14636	R or L
15 (1/2")	14536	R or L
20 (3/4")	14460	R or L
25 (1")	14396	R or L
32 (1 1/4")	14377	R or L

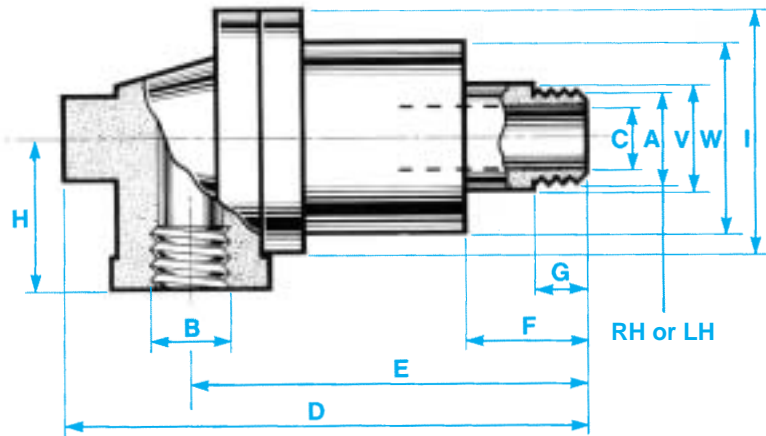

For double flow (stationary centre tube) type R.E./S.T.

Nominal Size	Part No.	
8 (1/4")	14643M	R or L
10 (3/8")	14637M	R or L
15 (1/2")	14535	R or L
20 (3/4")	14534	R or L
25 (1")	14542	R or L
32 (1 1/4")	14379	R or L

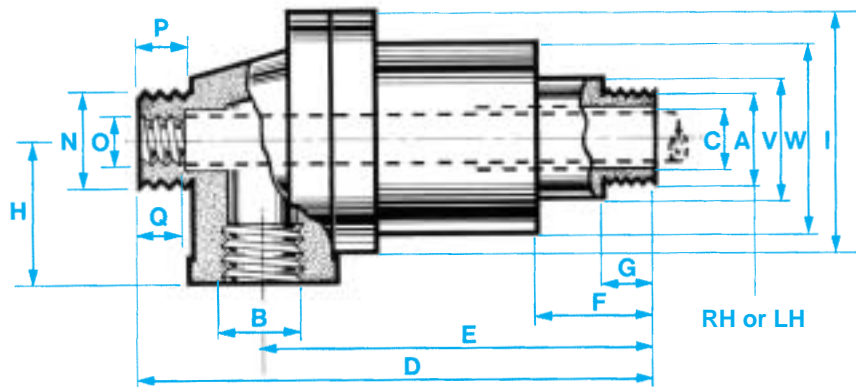

For double flow (rotary centre tube) type R.E./R.S.

Nominal Size	Part No.	
8 (1/4")	17196	R or L
10 (3/8")	17197	R or L
15 (1/2")	16657	R or L
20 (3/4")	16659	R or L
25 (1")	16661	R or L
32 (1 1/4")	16663	R or L

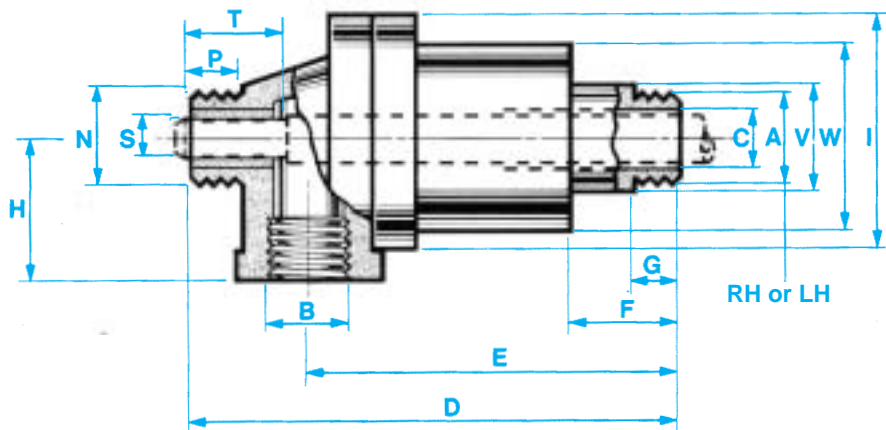

Dimensions in millimetres

Nominal Size	A & N	B	C	D	E	F	G & P	H	I	O	Q	S	T	V	W
8 (1/4")	G.1/4"		6	117	94	22	11	30	57	M5 x 0.8	6	4.75/ 4.72	25	24	44
10 (3/8")	G.3/8"		10	121	97	25	13	30	57	M6 x 1.0	6	6.35/ 6.32	25	24	44
15 (1/2")	G.1/2"		13	167	130	29	16	44	83	G.1/8"	6	9.52/ 9.50	40	38	63
20 (3/4")	G.3/4"		18	173	133	32	19	44	83	G.1/4"	10	12.70/ 12.67	40	38	63
25 (1")	G.1"		22	197	149	48	22	54	105	G.3/8"	10	15.87/ 15.85	45	43	83
32 (1 1/4")	G.1 1/4"		30	227	170	51	25	70	121	G.1/2"	13	19.05/ 19.02	50	55	95

'G' is the designation for parallel pipe threads to BS.2779 and ISO 228/1

SEE PAGE 28 FOR INSTALLATION INSTRUCTIONS

Rotary (P.B.) Union type S.T. (fitted with a bellow seal)

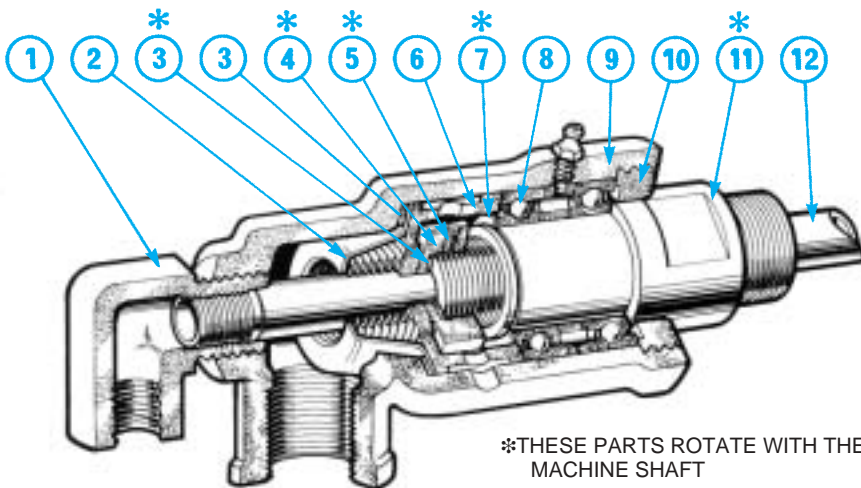

1. Elbow, brass.
2. Bellows sub-assembly, brazed stainless steel.
3. Gaskets.
4. Seal ring sub-assembly, steel/carbon.
5. Locking screw, h.t. steel.
6. Spacer.
7. Circlip.
8. Ball bearings.
9. Body, dZR brass.
10. Locking ring.
11. Rotary spindle, steel
12. Centre tube, if ordered, to customers specification.

Mechanical Seals are also available.
(add MS to the Part No)

The Rotary (P.B.) Union has been developed from the Rotary (R.E.) Union and utilises the same well-proven and highly successful bellows seal and bearing system. The body is manufactured from de-zincification resistant brass which has advantages over conventional brass and the cast iron adaptor of the Rotary (R.E.) Union on many water cooling applications. There are three types available which are shown in the diagrams on page 7 and described below (add MS to the Part No.).

TYPE P.B./B.E.

This Rotary (P.B.) Union is a single flow unit and is suitable for transferring fluids into or out of rotating machine shafts. The body is fitted with a plug at the outboard end which allows this type to be converted to P.B./S.T. or P.B./R.S. by using the appropriate elbow. A typical application is shown on page 3.

TYPE P.B./S.T.

This Rotary (P.B.) Union is fitted with an elbow suitable for double flow with a stationary centre tube. This gives flow areas through the centre tube and annulus. Centre tubes are only provided if ordered. The centre tube is fixed to the Rotary (P.B.) Union end by means of a screw thread shown as dimension 'O'. Flow can pass in through the centre tube and return through the annulus or be reversed.

For steam applications, a typical example of which is shown on page 3, the centre tube is curved to reach the condensate in the bottom of the cylinder. At times the roll neck diameter to length ratio prevents a curved tube being used, in such cases we can provide a Syphon Elbow details of which are on page 20.

TYPE P.B./R.S.

The elbow fitted to this Rotary (P.B.) Union is suitable for a rotating centre tube, which must be located and driven by the machine. Centre tubes are only provided if ordered. The centre tube rotates in a labyrinth bush. The centre tube "sealing" system allows a slight internal leakage between the supply and return lines. If these fluids must not mix then an alternative design can be provided, please ask our Technical Department. Flow can pass-in through the centre tube with the return through the annulus or be reversed. A typical application is shown on page 3.

Operational Guidelines (For other conditions contact Filton Limited)

FLUIDS

Water, mineral oils and compressed air (lubricated). All fluids should be clean and free from abrasive particles.

PRESSURE

17 bar maximum

VACUUM

740 mm Hg. maximum (specify vacuum and we will test for this).

TEMPERATURE

-20° to 160°C

SPEED

1000 r.p.m. maximum with the bellows seal, 1500 r.p.m. maximum with the mechanical seal.

FLOW CAPACITY

Nominal Size	Type	Water*		Air*
		m ³ /h	l/min	
15 (1/2")	B.E.	1.7	28.3	58
	S.T. & R.S.	0.3	5	10
20 (3/4")	B.E.	2.7	45	96
	S.T. & R.S.	0.6	10	22
25 (1")	B.E.	4.1	68.3	144
	S.T. & R.S.	1.8	30	44

* Flow in cubic metres/hour at a velocity of 3 metres/second.
Applies also to other liquids.

★ Flow in cubic metres/hour free air at a velocity of 15 metres/second and a pressure of 6 bar.

IT IS NOT ADVISABLE TO COMBINE MAXIMUMS

ROTARY (P.B.) UNIONS



The part numbers shown are for units fitted with the bellows seal. Add suffix MS if a mechanical seal is required.

For single flow type P.B./B.E.

Nom size	A	Part No	
15 (1/2")	G1/2"	18466	R or L
	3/4" - 16 UNF	18466U	R or L
	M22 x 1.5	18466MB	R or L
20 (3/4")	G3/4"	18469	R or L
	1" - 14 UNS	18469U	R or L
	M30 x 1.5	18469MB	R or L
25 (1")	G1"	18472	R or L
	1 1/2" - 12 UNF	18472U	R or L
	M35 x 1.5	18472MB	R or L

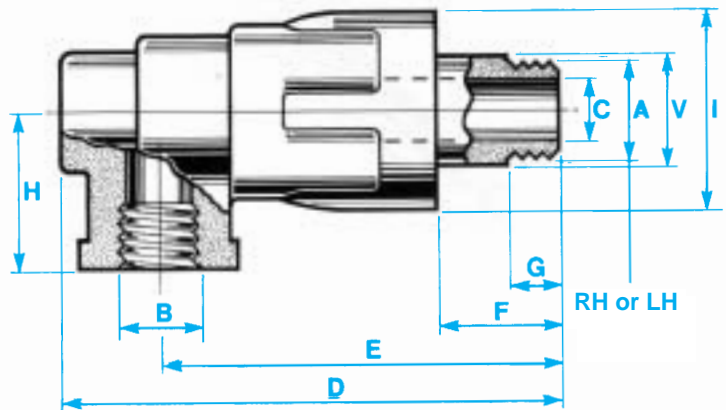

For double flow (stationary centre tube) type P.B./S.T.

Nom size	A	Part No	
15 (1/2")	G1/2"	18467	R or L
	3/4" - 16 UNF	18467U	R or L
	M22 x 1.5	18467MB	R or L
20 (3/4")	G3/4"	18470	R or L
	1" - 14 UNS	18470U	R or L
	M30 x 1.5	18470MB	R or L
25 (1")	G1"	18473	R or L
	1 1/2" - 12 UNF	18473U	R or L
	M35 x 1.5	18473MB	R or L

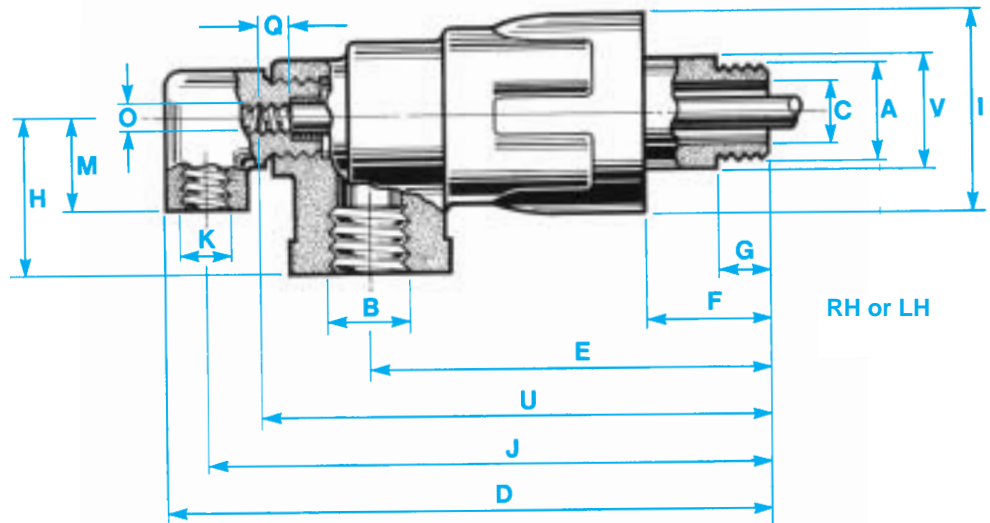

For double flow (rotary centre tube) type P.B./R.S.

Nom size	A	Part No	
15 (1/2")	G1/2"	18468	R or L
	3/4" - 16 UNF	18468U	R or L
	M22 x 1.5	18468MB	R or L
20 (3/4")	G3/4"	18471	R or L
	1"-14 UNS	18471U	R or L
	M30 x 1.5	18471MB	R or L
25 (1")	G1"	18474	R or L
	1 1/2" - 12 UNF	18474U	R or L
	M35 x 1.5	18474MB	R or L

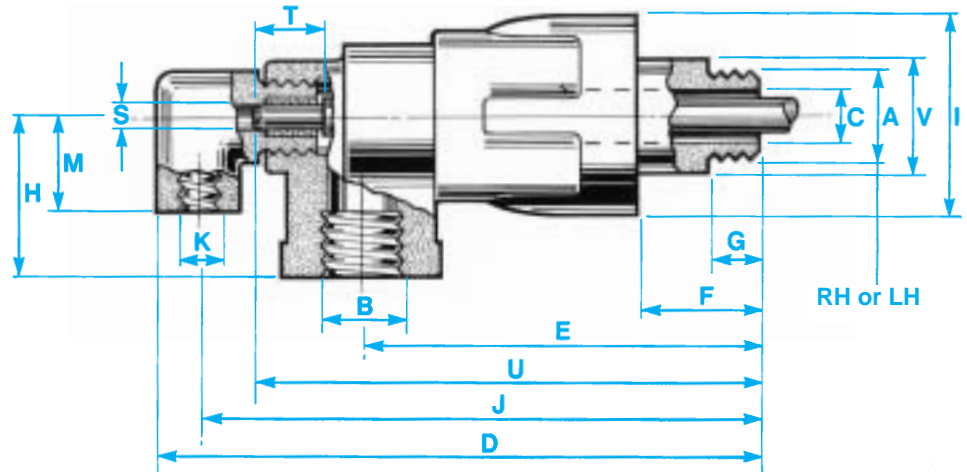

Dimensions in millimetres

Nominal size	B	C	D B.E.	D S.T. & R.S.	E	F	G	H	I	J	K	M	O	Q	S	T	U S.T.	U R.S.	V
15 (1/2")	G1/2"	13	159	193	130	29	16	44	68	181	G1/4"	30	G1/8"	12	9.52/9.50	20	173	166	38
20 (3/4")	G3/4"	18	162	196	133	32	19	44	68	184	G1/4"	30	G1/4"	12	12.70/12.67	20	176	169	38
25 (1")	G1"	22	180	210	148	43	22	52	88	197	G3/8"	25	G3/8"	9.5	15.87/15.85	25	185	185	42

For dimension 'A' see the part No tables above

'G' is the designation for parallel pipe threads to BS.2779 and ISO.228/1

SEE PAGE 28 FOR INSTALLATION INSTRUCTIONS

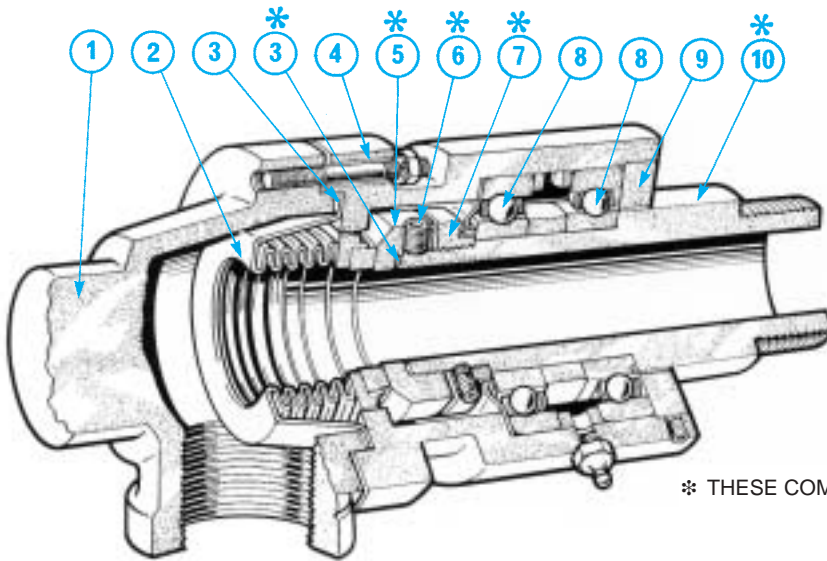

Rotary (R.E.B.) Union type B.E.

1. Adaptor, s.g. iron.
2. Bellows sub-assy, brazed stainless steel/carbon.
3. Gaskets.
4. Body, s.g. iron.
5. Seal ring, hardened stainless steel.
6. Locking screws, h.t. steel.
7. Locking ring-inner.
8. Ball bearings—shielded from the seal chamber.
9. Locking ring-outer.
10. Rotary spindle, steel.

※ THESE COMPONENTS ROTATE WITH THE SHAFT

The Rotary (R.E.B.) Union is a self contained, self supporting rotary seal for the leak proof transfer of fluids (such as steam, water, air or oil) to and from rotating machine shafts.

The type of Rotary Seal fitted to the Rotary (R.E.B.) Union is a "FILTON BELLOWS SEAL" containing a flexible stainless steel bellows which is self adjusting, eliminating the maintenance common with conventional packed glands.

Rotary sealing is created by relative rotation between extremely flat sealing faces (items 2 and 5) held in contact by the spring characteristics of the bellows with an additional sealing force created by pressure of the fluid passing through the Rotary (R.E.B.) Union.

The bearings fitted to the Rotary (R.E.B.) Union are standard ball bearings which are given their initial lubrication after assembly. A shield is fitted to the seal chamber side of the ball bearings.

There are 3 variations of the stationary Adaptor end, diagrams on page 9 and described below:-

TYPE R.E.B./B.E.

This is a single flow unit and is suitable for transferring fluid in to or out of rotating machines. A typical application for this type is shown in page 3.

TYPE R.E.B./S.T

This Rotary (R.E.B.) Union is fitted with an Adaptor suitable for double flow with a stationary centre tube. This gives flow areas through the centre tube and annulus. Centre tubes are only provided if ordered. The centre tube is fixed to the Rotary (R.E.B.) Union end by means of a screw thread shown as dimension 'O'. Flow can pass in through the centre tube and return through the annulus or be reversed. For steam applications, a typical example of which is shown on page 3, the centre tube is curved to reach the condensate in the bottom of the cylinder. At times the roll neck diameter to length ratio prevents a curved tube being used, in such cases we can provide a Syphon Elbow details of which are on page 20.

TYPE R.E.B./R.S.

The Adaptor fitted to this Rotary (R.E.B.) Union is suitable for a rotating centre tube, which must be located and driven by the machine. Centre tubes are only provided if ordered. The centre tube rotates in a carbon bush. The centre tube "sealing" system allows a slight internal leakage between the supply and return lines. If these fluids must not mix then an alternative design can be provided. Please ask our Technical Department. Flow can pass-in through the centre tube with the return through the annulus or be reversed. A typical application is shown on page 3.

Operational Guidelines (For other conditions contact Filton Limited)

FLUIDS

Water, steam, mineral oils, heat transfer fluids and compressed air (lubricated). All fluids should be clean and free from abrasive particles.

PRESSURE

- Water, steam and mineral oil - 17 bar maximum.
- Heat transfer fluid - 17 bar maximum (5" and 6" 13 bar maximum.)
- Compressed air - 1 1/2" & 2" - 17 bar maximum
- 2 1/2" & 3" - 12.5 bar maximum
- 3 1/2" & 4" - 10 bar maximum
- 5" & 6" - On application

VACUUM

740 mm Hg. maximum (specify vacuum and we will test for this).

TEMPERATURE

- 20° to 180°C (with suitable effective lubrication 200°C).
- 20° to 120°C for sizes 125 (5") and 150 (6").

SPEED

600 r.p.m. maximum up to 50 (2") size, 500 r.p.m. for 65 (2 1/2") and 80 (3"), 400 r.p.m. for 90 (3 1/2") and 100 (4") and 300 r.p.m. for 125 (5") and 150 (6").

* Flow in Cubic metres/hour at a velocity of 3 metres/second. Applies also to other liquids

† Flow in kilograms/hour at a velocity of 30 metres/second and a pressure of 6 bar.

★ Flow in cubic metres/hour free air at a velocity of 15 metres/second and a pressure of 6 bar.

FLOW CAPACITY

Nominal Size	Type	Water*		Steam† kg/h	Air★ m³/h
		m³/h	l/min		
40 (1 1/2")	B.E.	10.4	173	381	364
	S.T. & R.S.	3.8	63	151	135
50 (2")	B.E.	19.5	325	717	684
	S.T. & R.S.	6.3	105	357	215
65 (2 1/2")	B.E.	30.5	508	1120	1069
	S.T. & R.S.	10.8	180	547	376
80 (3")	B.E.	41.6	693	1524	1455
	S.T. & R.S.	14.9	248	807	511
90 (3 1/2")	B.E.	57.0	950	2091	1996
	S.T. & R.S.	23.4	390	942	818
100 (4")	B.E.	76.6	1277	2807	2679
	S.T. & R.S.	27.6	460	982	937
125 (5")	B.E.	112.2	1870	4859	4639
	S.T. & R.S.	45.3	755	1617	1544
150 (6")	B.E.	166.3	2772	6997	6680
	S.T. & R.S.	73.7	1228	2892	2760

IT IS NOT ADVISABLE TO COMBINE MAXIMUMS

ROTARY (R.E.B.) UNIONS

FILTON

For single flow type R.E.B./B.E.

Normal Size	Part No.	
40 (1 1/2")	18104	R or L
50 (2")	17350	R or L
65 (2 1/2")	18131	R or L
80 (3")	17265	R or L
90 (3 1/2")	17421	R or L
100 (4")	17424	R or L
125 (5")	17634.SF	R or L
150 (6")	17637.SF	R or L

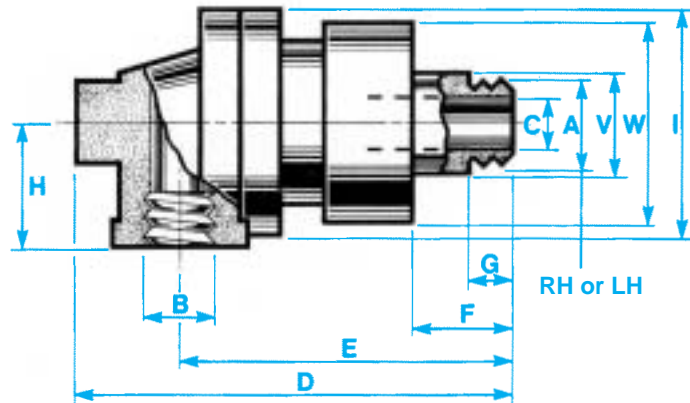

For double flow (stationary centre tube) type R.E.B./S.T.

Nominal Size	Part No.	
40 (1 1/2")	18105	R or L
50 (2")	17238	R or L
65 (2 1/2")	18132	R or L
80 (3")	17266	R or L
90 (3 1/2")	17422	R or L
100 (4")	17425	R or L
125 (5")	17635.SF	R or L
150 (6")	17638.SF	R or L

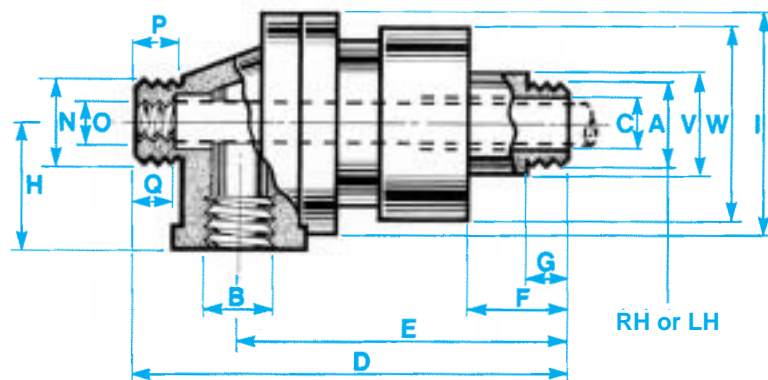

For double flow (rotary centre tube) type R.E.B./R.S.

Nominal Size	Part No.	
40 (1 1/2")	18106	R or L
50 (2")	17351	R or L
65 (2 1/2")	18133	R or L
80 (3")	17263	R or L
90 (3 1/2")	17423	R or L
100 (4")	17426	R or L
125 (5")	17636.SF	R or L
150 (6")	17639.SF	R or L

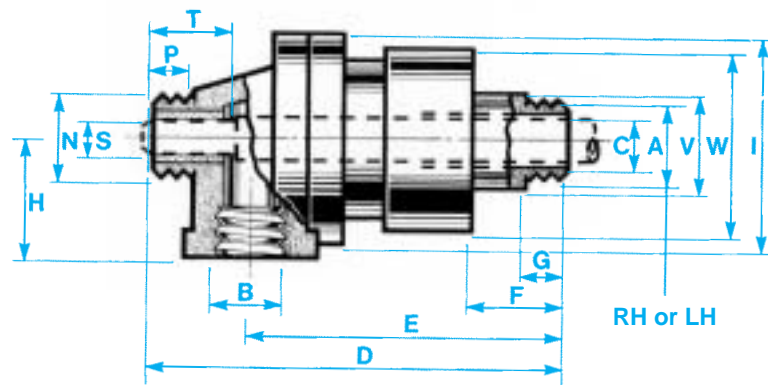

Dimensions in millimetres

Nominal Size	A	B & N	C	D	E	F	G & P	H	I	O	Q	S*	T	V	W
40(1 1/2")	G.1 1/2"	G.1 1/2"	35	268	212	52	25	72	128	G. 3/4"	14	25.4,f8	50	64	108
50(2")	G.2"	G.2"	48	293	226	55	28	83	137	G.1"	19	31.8,f8	60	76	127
65(2 1/2")	G.2 1/2"	G.2 1/2"	57	357	279	67	30	102	186	G.1 1/4"	25	40,f8	55	90	150
80(3")	G.3"	G.3"	70	409	324	77	30	120	200	G.1 1/2"	25	45,f8	70	110	180
90(3 1/2")	G.3 1/2"	G.4"	82	519	406	95	40	130	250	G.2"	30	60,f8	60	140	240
100(4")	G.4"	G.4"	95	519	406	95	40	130	250	G.2 1/2"	30	75,f8	60	140	240
125(5")	●	G.5"	115	688	543	115	45	167	325	G.3"	40	88,f8	70	192	290
150(6")	●	G.6"	140	688	543	115	45	167	325	G.3 1/2"	40	100,f8	70	192	290

● Flanged, see page 23.

* The tolerance f8 is to I.S.O. 286-2 and BS.EN 20286-2

'G' is the designation for parallel pipe threads to BS.2779 and ISO 228/1.

SEE PAGE 28 FOR INSTALLATION INSTRUCTIONS

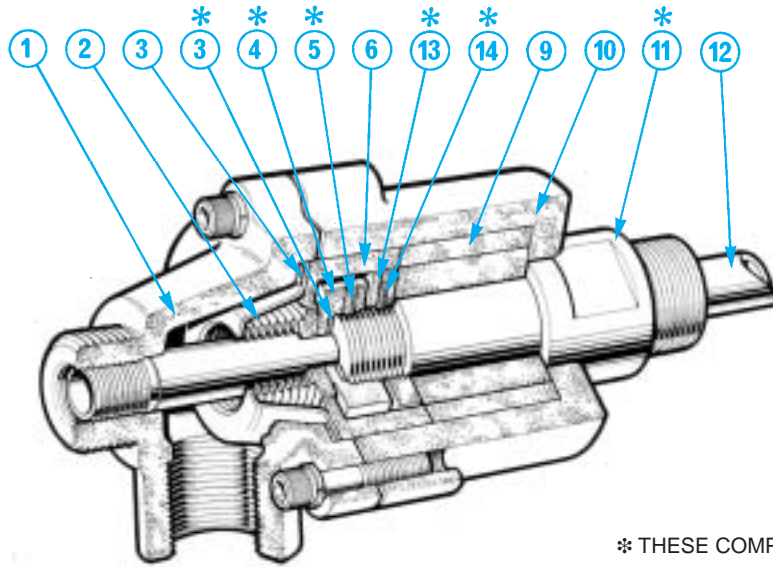

Rotary (C.B.) Union type S.T.

1. Adaptor, high quality cast iron.
2. Bellows sub-assembly. brazed stainless steel.
3. Gaskets.
4. Seal ring sub-assembly, steel/carbon.
5. Locking screw, h.t. steel.
6. Spacer.
9. Bearing sub-assembly, steel/carbon.
10. Body, high quality cast iron.
11. Rotary spindle, steel.
12. Centre tube, if ordered, to your specification.
13. Thrust Pad, stainless steel.
14. Set screw, h.t. steel.

* THESE COMPONENTS ROTATE WITH THE MACHINE SHAFT

The Rotary (C.B.) Union is a self contained, self supporting rotary seal for the leak proof transfer of fluids (such as steam, hot water or oil) to and from rotating machine shafts.

The type of Rotary Seal fitted to the Rotary (C.B.) Union is a "FILTON BELLOWS SEAL" containing a flexible stainless steel bellows which is self adjusting, eliminating the maintenance common with conventional packed glands. Rotary sealing is created by relative rotation between extremely flat sealing faces (items 2 and 4) held in contact by the spring characteristics of the bellows with an additional sealing force created by pressure of the fluid passing through the Rotary (C.B.) Union. The bearing fitted to the Rotary (C.B.) Union is a cylindrical carbon combined journal and thrust bearing in which a hard chromed and ground spindle rotates.

There are 3 variations of the stationary Adaptor end, diagrams on page 11 and described below:-

TYPE C.B./B.E.

This is a single flow unit and is suitable for transferring fluid in to or out of rotating machines. A typical application is shown on page 3.

TYPE C.B./S.T.

This Rotary (C.B.) Union is fitted with an Adaptor suitable for double flow with a stationary centre tube. This gives flow areas through the centre tube and annulus. Centre tubes are only provided if ordered. The centre tube is fixed to the Rotary (C.B.) Union end by means of a screw thread shown as dimension 'O'. Flow can pass in through the centre tube and return through the annulus or be reversed.

For steam applications, a typical example of which is shown on page 3, the centre tube is curved to reach the condensate in the bottom of the cylinder. At times the roll neck diameter to length ratio prevents a curved tube being used, in such cases we can provide a Syphon Elbow details of which are on page 20.

TYPE C.B./R.S.

The Adaptor fitted to this Rotary (C.B.) Union is suitable for a rotating centre tube, which must be located and driven by the machine. Centres tubes are only provided if ordered. The centre tube rotates in a bush. The centres tube "sealing" system allows a slight internal leakage between the supply and return lines. If these fluids must not mix then an alternative design can be provided. Please ask our Technical Department. Flow can pass through the centre tube with the return through the annulus or be reversed. A typical application is shown on page 3.

Operational Guidelines (For other conditions contact Filton Limited)

FLUIDS

Water, steam, mineral oils and heat transfer fluids (but use flanged connections when the temperature exceeds 180°C). All fluids should be clean and free from abrasive particles.

PRESSURE

17 bar maximum.

TEMPERATURE

100°C to 300°C (lower temperatures dependant on other conditions).

SPEED

500 r.p.m. maximum up to 25(1") size and 400 r.p.m. for 32 (1 1/4").

FLOW CAPACITY

Nominal Size	Type	Water*		Steam† kg/h
		m³/h	l/min	
8 (1/4")	B.E.	0.3	5	11
	S.T. & R.S.	0.05	0.8	3.4
10 (3/8")	B.E.	0.8	13.3	31
	S.T. & R.S.	0.1	1.7	16
15 (1/2")	B.E.	1.7	28.3	61
	S.T. & R.S.	0.3	5	27
20 (3/4")	B.E.	2.7	45	101
	S.T. & R.S.	0.6	10	41
25 (1")	B.E.	4.1	68.3	151
	S.T. & R.S.	1.8	30	56
32 (1 1/4")	B.E.	7.6	127	280
	S.T. & R.S.	2.1	35	133

* Flow in cubic metres/hour at a velocity of 3 metres/second. Applies also to other liquids.

† Flow in kilograms/hour at a velocity of 30 metres/second and a pressure of 6 bar.

IT IS NOT ADVISABLE TO COMBINE MAXIMUMS

ROTARY (C.B.) UNIONS

FILTON

For single flow type C.B./B.E.

Nominal Size	Part No.	R or L
8 (1/4")	14645	R or L
10 (3/8")	14639	R or L
15 (1/2")	14554	R or L
20 (3/4")	14524	R or L
25 (1")	14545	R or L
32 (1 1/4")	14546	R or L

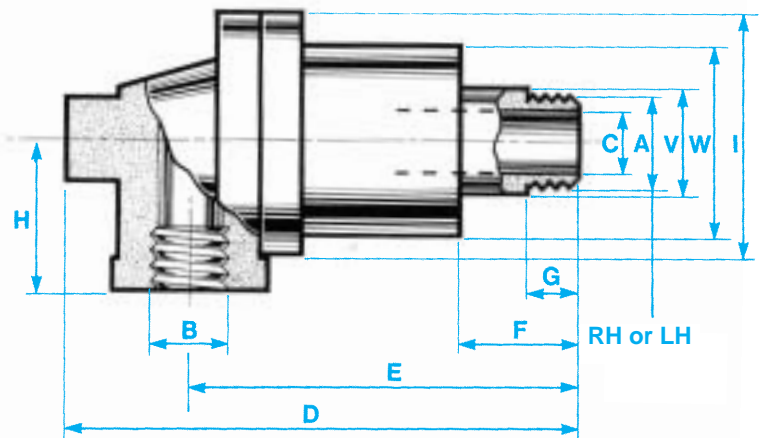

For double flow (stationary centre tube) type C.B./S.T.

Nominal Size	Part No.	R or L
8 (1/4")	14646M	R or L
10 (3/8")	14640M	R or L
15 (1/2")	14525	R or L
20 (3/4")	14523	R or L
25 (1")	14386	R or L
32 (1 1/4")	14488	R or L

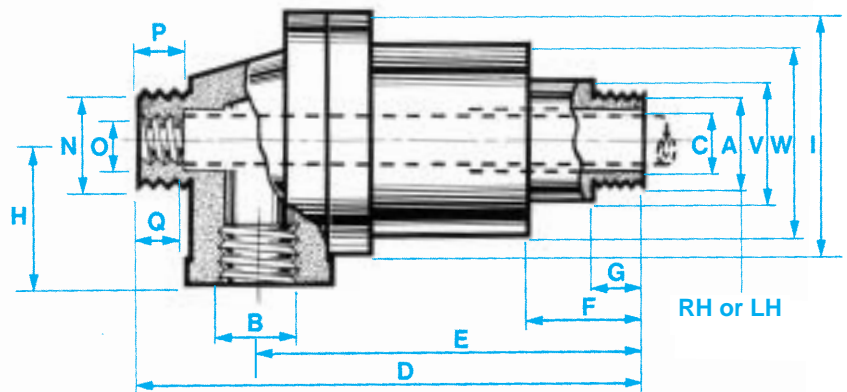

For double flow (rotary centre tube) type C.B./R.S.

Nominal Size	Part No.	R or L
8 (1/4")	17215	R or L
10 (3/8")	17216	R or L
15 (1/2")	16658	R or L
20 (3/4")	16660	R or L
25 (1")	16662	R or L
32 (1 1/4")	16664	R or L

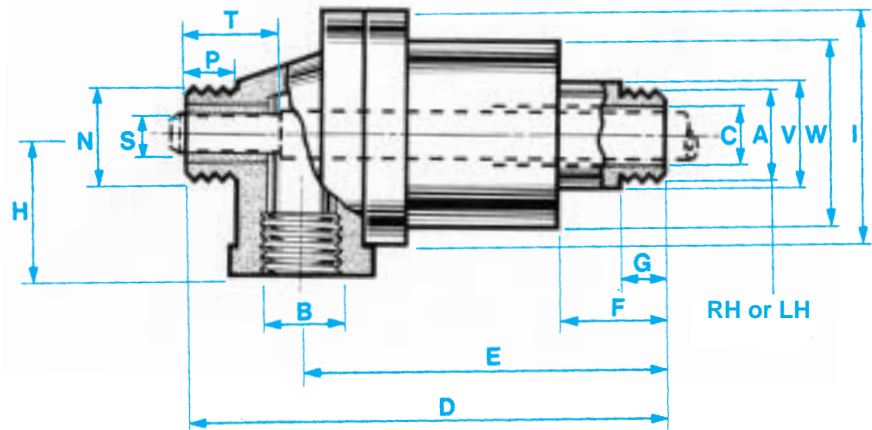

Dimensions in millimetres

Nominal Size	A B & N	C	D	E	F	G & P	H	I	O	Q	S	T	V	W
8 (1/4")	G.1/4"	6	117	94	22	11	30	57	M5 x 0.8	6	4.75/ 4.72	25	24	44
10 (3/8")	G.3/8"	10	121	97	25	13	30	57	M6 x 1.0	6	6.35/ 6.32	25	24	44
15 (1/2")	G.1/2"	13	167	130	29	16	44	83	G.1/8"	6	9.52/ 9.50	40	38	63
20 (3/4")	G.3/4"	18	173	133	32	19	44	83	G.1/4"	10	12.70/ 12.67	40	38	63
25 (1")	G.1"	22	210	162	48	22	54	105	G.3/8"	10	15.87/ 15.85	45	43	83
32 (1 1/4")	G.1 1/4"	30	238	181	51	25	70	121	G.1/2"	13	19.05/ 19.02	50	55	95

'G' is the designation for parallel pipe threads to BS.2779 and ISO 228/1.

SEE PAGE 28 FOR INSTALLATION INSTRUCTIONS



ROTARY (C.B.N.) UNIONS

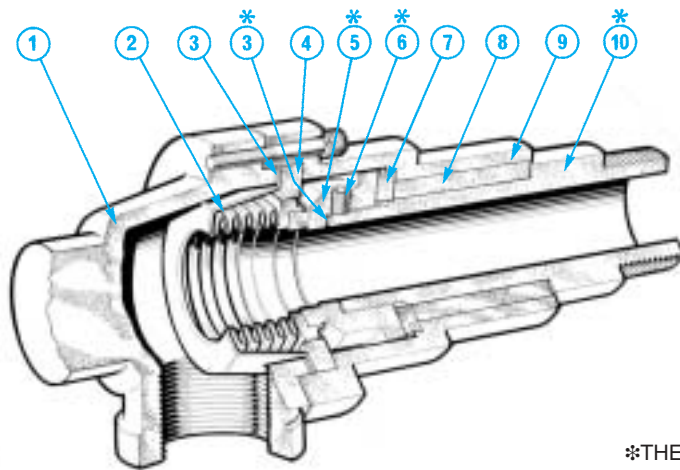

Rotary (C.B.N.) Union type B.E.

1. Adaptor, s.g. iron.
2. Bellows sub-assembly brazed stainless steel/carbon.
3. Gaskets.
4. Spacer, plated steel.
5. Seal ring, hardened stainless steel.
6. Locking screw, h.t. steel.
7. Thrust bearing, carbon.
8. Journal bearing, carbon.
9. Body, s.g. iron.
10. Rotary spindle, steel.

*THESE COMPONENTS ROTATE WITH THE SHAFT

The Rotary (C.B.N.) Union is a self contained, self supporting rotary seal for the leak proof transfer of fluids (such as steam, hot water or oil) to and from rotating machine shafts.

The type of Rotary Seal fitted to the Rotary (C.B.N.) Union is a "FILTON BELLOWS SEAL" containing a flexible stainless steel bellows which is self adjusting, eliminating the maintenance common with conventional packed glands.

Rotary sealing is created by relative rotation between extremely flat sealing faces (items 2 and 5) held in contact by the spring characteristic of the bellows with an additional sealing force created by pressure of the fluid passing through the Rotary (C.B.N.) Union.

The bearings fitted to the Rotary (C.B.N.) Union are separate carbon thrust and journal bearings in which a hard chromed and ground spindle rotates.

There are 3 variations of the stationary Adaptor end, diagrams on page 13 and described below:—

TYPE C.B.N./B.E.

This is a single flow unit and is suitable for transferring fluid in to or out of rotating machines shafts. A typical application for this type is shown on page 3.

TYPE C.B.N./S.T.

This Rotary (C.B.N.) Union is fitted with an Adaptor suitable for double flow with a stationary centre tube. This gives flow areas through the centre tube and annulus. Centre tubes are only provided if ordered. The centre tube is fixed to the Rotary (C.B.N.) Union end by means of a screw thread shown as dimension 'O'. Flow can pass in through the centre tube and return through the annulus or be reversed.

For steam applications, a typical example of which is shown on page 3, the centre tube is curved to reach the condensate in the bottom of the cylinder. At times the roll neck diameter to length ratio prevents a curved tube being used, in such cases we can provide a Syphon Elbow, details of which are on page 20.

TYPE C.B.N./R.S.

The Adaptor fitted to this Rotary (C.B.N.) Union is suitable for a rotating centre tube, which must be located and driven by the machine. Centre tubes are only provided if ordered. The centre tube rotates in a carbon bush. The centre tube "sealing" system allows a slight internal leakage between the supply and return lines. If these fluids must not mix then an alternative design can be provided. Please ask our Technical Department. Flow can pass in through the centre tube with the return through the annulus or be reversed. A typical application is shown on page 3.

Operational Guidelines (For other conditions contact Filton Limited)

FLUIDS

Hot water, steam, mineral oils, heat transfer fluids (but use flanged connections when the temperature exceeds 180°C).
All fluids should be clean and free from abrasive particles.

PRESSURE

Water, steam and mineral oil - 17 bar maximum.
Heat transfer fluid - 17 bar maximum (5" and 6" 13 bar maximum.)

TEMPERATURE

100°C to 300°C (lower temperatures dependant on other conditions).

SPEED

300 r.p.m. maximum up to 50 (2") size, 250 r.p.m. for 65 (2½") and 80 (3"), 200 r.p.m. 90 (3½") and 100 (4"), and 150 r.p.m. for 125 (5") and 150 (6").

* Flow in cubic metres/hour at a velocity of 3 metres/second.
Applies also to other liquids.

† Flow in kilograms/hour at a velocity of 30 metres/second and a pressure of 6 bar.

FLOW CAPACITY

Nominal Size	Type	Water*		Steam†
		m³/h	l/min	
40 (1½")	B.E.	10.4	173	381
	S.T. & R.S.	3.8	63	151
50 (2")	B.E.	19.5	325	717
	S.T. & R.S.	6.3	105	357
65 (2½")	B.E.	30.5	508	1120
	S.T. & R.S.	10.8	180	547
80 (3")	B.E.	41.6	693	1524
	S.T. & R.S.	14.9	248	807
90 (3½")	B.E.	57.0	950	2091
	S.T. & R.S.	23.4	390	942
100 (4")	B.E.	76.6	1277	2807
	S.T. & R.S.	27.6	460	982
125 (5")	B.E.	112.2	1870	4859
	S.T. & R.S.	45.3	755	1617
150 (6")	B.E.	166.3	2772	6997
	S.T. & R.S.	73.7	1228	2892

IT IS NOT ADVISABLE TO COMBINE MAXIMUMS

ROTARY (C.B.N.) UNIONS



Specify R or L with the part No to suit thread 'A' and the direction of rotation

For single flow type C.B.N./B.E.

Nominal Size	Part No.	R or L
40 (1 1/2")	18101	R or L
50 (2")	15471	R or L
65 (2 1/2")	18240	R or L
80 (3")	15477	R or L
90 (3 1/2")	16171	R or L
100 (4")	16174	R or L
125 (5")	15486.SF	R or L
150 (6")	16704.SF	R or L

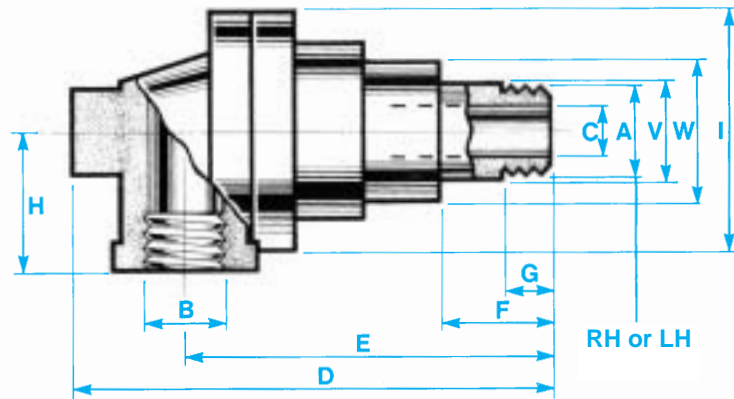

For double flow (stationary centre tube) type C.B.N./S.T.

Nominal Size	Part No.	R or L
40 (1 1/2")	18102	R or L
50 (2")	15472	R or L
65 (2 1/2")	18241	R or L
80 (3")	15478	R or L
90 (3 1/2")	16172	R or L
100 (4")	16175	R or L
125 (5")	15487.SF	R or L
150 (6")	16703.SF	R or L

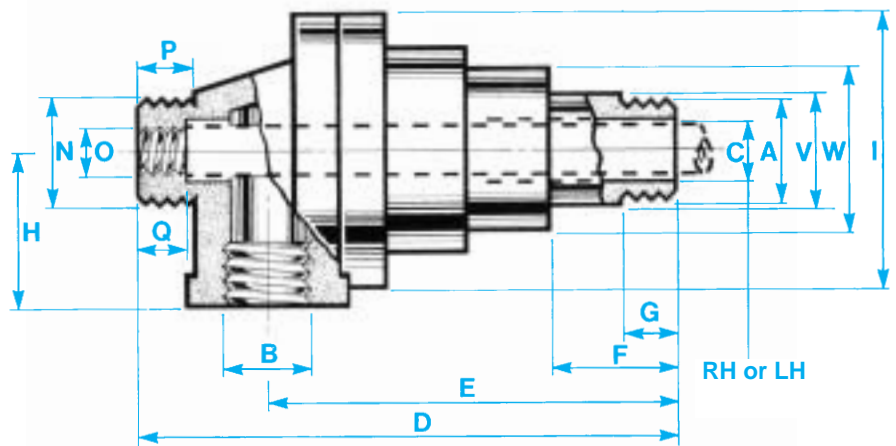

For double flow (rotary centre tube) type C.B.N./R.S.

Nominal Size	Part No.	R or L
40 (1 1/2")	18103	R or L
50 (2")	15473	R or L
65 (2 1/2")	18242	R or L
80 (3")	15479	R or L
90 (3 1/2")	16173	R or L
100 (4")	16176	R or L
125 (5")	15488.SF	R or L
150 (6")	16702.SF	R or L

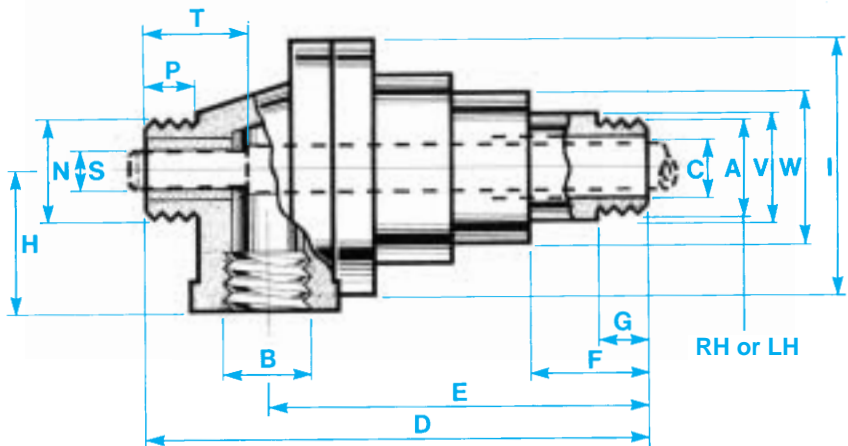

Dimensions in millimetres

Nominal Size	A	B & N	C	D	E	F	G & P	H	I	O	Q	S*	T	V	W
40 (1 1/2")	G.1 1/2"	G.1 1/2"	35	263	207	56	25	72	128	G.3/4"	14	25.4,f8	50	64	78
50 (2")	G.2"	G.2"	48	293	226	64	28	83	137	G.1"	19	31.8,f8	60	76	94
65 (2 1/2")	G.2 1/2"	G.2 1/2"	57	356	278	75	30	102	186	G.1 1/4"	25	40,f8	55	90	112
80 (3")	G.3"	G.3"	70	407	323	80	30	120	200	G.1 1/2"	25	45,f8	70	110	130
90 (3 1/2")	G.3 1/2"	G.4"	82	518	405	110	40	130	250	G2"	30	60,f8	60	140	160
100 (4")	G.4"	G.4"	95	518	405	110	40	130	250	G.2 1/2"	30	75,f8	60	140	160
125 (5")	•	G.5"	115	688	513	115	45	167	325	G.3"	40	88,f8	70	192	220
150 (6")	•	G.6"	140	688	513	115	45	167	325	G.3 1/2"	40	100,f8	70	192	220

● Flanged, see page 23.

*The tolerance f8 is to I.S.O 286-2 and BS.EN 20286-2

"G" is the designation for parallel pipe threads to B.S.2779 & I.S.O. 228/1.

SEE PAGE 28 FOR INSTALLATION INSTRUCTIONS

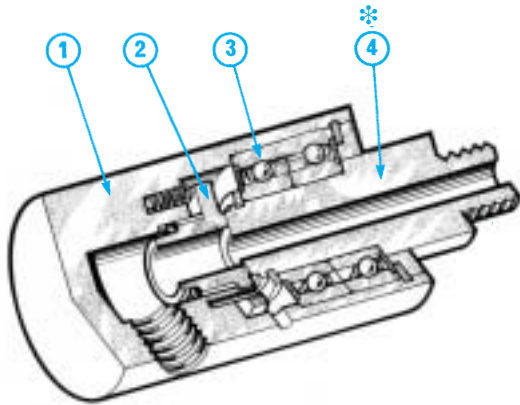

Rotary (L.C.) Union Type B.E.

- 1. Body.
- 2. Mechanical seal assembly.
- 3. Ball bearings - life lubricated.
- 4. Rotary spindle.

※ THIS PART ROTATES WITH THE SHAFT

The Rotary (L.C.) Union is intended to light duty applications and is of a simple design using the minimum amount of parts. It is not intended as a unit that can be repaired, though this is possible. For low pressures, temperatures and modest speeds with occasional use it is ideal.

For continuous use and easy reparability we recommend the Rotary (R.E.) Union (see page 4), or the Rotary (P.B.) Union (see page 6). The Rotary (L.C.) Union is also useful if there are space limitations, for example where two rotary shafts are close together, or there is limited space between the shaft end and the machine frame. There are two different types available:-

TYPE L.C./B.E.

This rotary (L.C.) Union is a single flow unit suitable for transferring fluid into or out of a rotating machine shaft.

TYPE L.C./S.T.

This Rotary (L.C.) Union has the body end tapped to receive a stationary centre tube. This gives flow areas through the centre tube and through the annulus, therefore supply and return of fluid at one end of the machine shaft is possible. Centre tubes are only provided if specified and ordered.

The centre tube should be threaded to pass through the body end and to suit dimension 'O'. An elbow should be fitted onto the tube end matching dimension 'O'. For the 8 (1/4") and 10 (3/8") nominal sizes a pipe thread is impossible. It is therefore necessary to adapt from dimension 'O' to suit a G1/8" or G1/4" Elbow.

Operational Guidelines (For other conditions contact Filton Limited)

FLUIDS: Water, mineral oil and lubricated air (all fluids must be free of abrasives)

PRESSURE: (max) 10 bar

VACUUM: (max) 740 mmHg

TEMPERATURE: -20° to 75°C.

SPEED: (max) 2000 rpm

TYPE B.E.

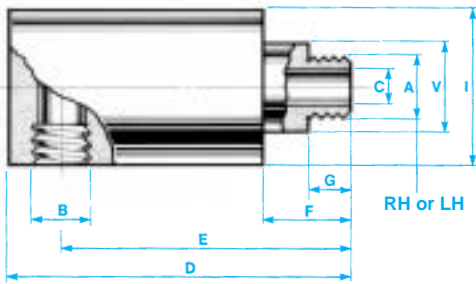

TYPE S.T.

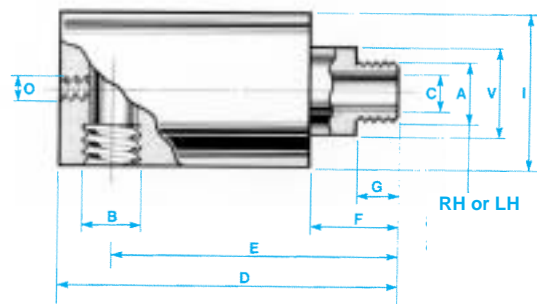

Dimensions in millimetres

Nom. Size	Part No*		A	B	C	D	E	F	G	I	O	V
	Type B.E.	Type S.T.										
8 (1/4")	18070	18110	G1/4"	R1/4"	6	90	78	24	11	40	M5 x 0.8	24
	18070U	18110U	1/2" - 20 UNF									
	18070MB	18110MB	M12 x 1.25									
10 (3/8")	18071	18111	G3/8"	R3/8"	10	99	82	26	13	40	M6 x 1.0	24
	18071U	18111U	5/8" - 18 UNF									
	18071MB	18111MB	M15 x 1.5									
15 (1/2")	18073	18112	G1/2"	R1/2"	13	127	107	32	16	65	G1/8	38
	18073U	18112U	3/4" - 16 UNF									
	18073MB	18112MB	M22 x 1.5									
20 (3/4")	18074	18113	G3/4"	R3/4"	17.5	130	110	35	19	65	G1/4	38
	18074U	18113U	1"-14 UNS									
	18074MB	18113MB	M30 x 1.5									

* Add the suffix R for a RH spindle thread 'A'

Add the suffix L for a LH spindle thread 'A'

SEE PAGE 28 FOR INSTALLATION INSTRUCTIONS

ROTARY (P.N.) UNIONS

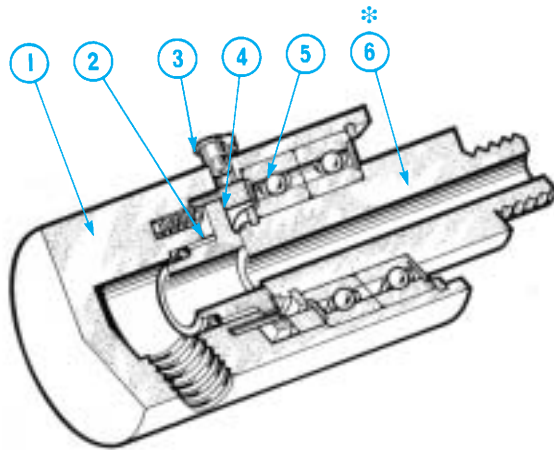

The Rotary (P.N.) Union

1. Body.
2. Mechanical seal assembly.
3. Seal face lubricator.
4. Oil reservoir.
5. Ball bearing - life lubricated.
6. Rotary spindle.

※ THIS PART ROTATES WITH THE SHAFT

The Rotary (P.N.) Union has the same basic design as the Rotary (L.C.) Union but incorporates an oil lubrication reservoir for seal face lubrication. This unit is intended for use on pneumatic applications where the compressed air is dry. This unit may also be advantageous compared to the Rotary (L.C.) Union even on lubricated air systems where speeds are high and only occasional pneumatic cycles are in use. Under these conditions very little lubricant reaches the seal faces and is quickly dissipated by the seal face temperatures created by natural friction. Pneumatic applications are, in the main, single flow consequently only this type is offered. Should your application require double flow, please contact our Technical Department.

Operational Guidelines: (For other conditions contact Filton Limited)

FLUID

Compressed air

PRESSURE

(Max) 10 bar,

VACUUM

Max 740mmHg

TEMPERATURE

5° to 75°C.

SPEED

Max 2500 rpm

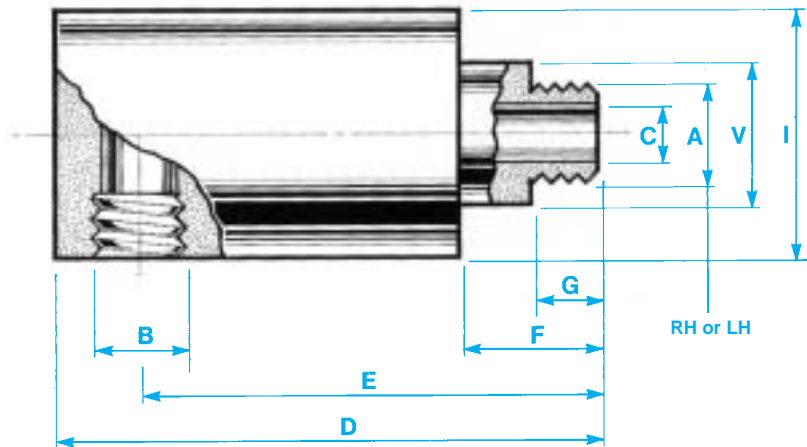

IT IS NOT ADVISABLE TO COMBINE MAXIMUMS

Dimensions in millimetres

Nom. Size	Part No *	A	B	C	D	E	F	G	I	V
8 (1/4")	18400	G1/4"	R1/4"	6	90	78	24	11	40	24
	18400U	1/2"-20 UNF								
	18400MB	M12 x 1.25								
10 (3/8")	18401	G3/8"	R3/8"	10	99	82	26	13	40	24
	18401U	5/8"-18 UNF								
	18401MB	M15 x 1.5								
15 (1/2")	18402	G1/2"	R1/2"	13	127	107	32	16	65	38
	18402U	3/4"-16 UNF								
	18402MB	M22 x 1.5								
20 (3/4")	18403	G3/4"	R3/4"	17.5	130	110	35	19	65	38
	18403U	1"-14 UNS								
	18403MB	M30 x 1.5								

* Add the suffix R for RH spindle thread 'A'

Add the suffix L for LH spindle thread 'A'

SEE PAGE 28 FOR INSTALLATION INSTRUCTIONS

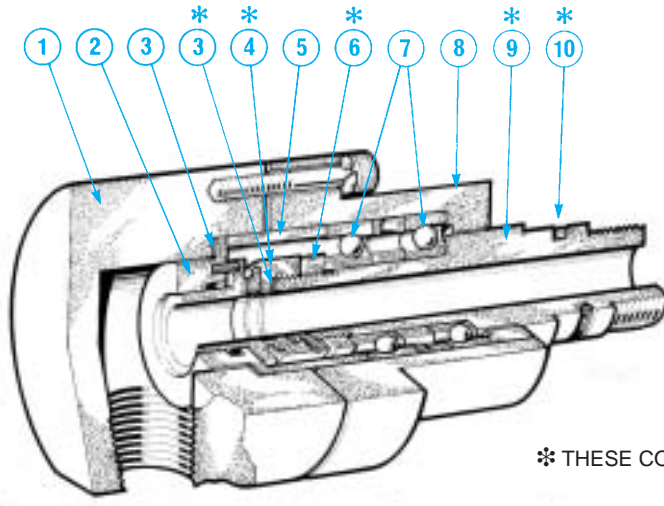

Rotary (M.C.T.) Union type B.E. with locating spigot

1. Adaptor, aluminium alloy.
2. Mechanical seal sub-assembly.
3. Gaskets.
4. Seal ring sub-assembly.
5. Spacer, plated steel.
6. Locking ring, steel.
7. Angular contact ball bearings.
8. Body aluminium alloy.
9. Rotary spindle, plated steel.
10. 'O' Ring, synthetic rubber.

* THESE COMPONENTS ROTATE WITH THE SHAFT

The Rotary (M.C.T.) Union is mainly intended for use on machine tools for the transfer of fluids (such as oil and air) to and from rotating shafts for air and hydraulic chucks, brakes, clutches, etc.

The type of Rotary Seal fitted to the Rotary (M.C.T.) Union is a "FILTON BALANCED MECHANICAL SEAL", containing multiple helical coil springs. The seal face materials are normally carbon against stainless steel. For applications on machine tool coolants where traces of abrasive particles may be present we recommend tungsten carbide seals. If required add code T.C. to the part number.

Rotary sealing is created by relative rotation between extremely flat sealing faces (items 2 and 4) held in contact by the helical coil springs and an additional sealing force created by the pressure of the fluid passing through the Rotary (M.C.T.) Union.

The Rotary (M.C.T.) Union is fitted with a matched pair of pre-loaded angular contact ball bearings lubricated for life with a special grease.

A double range of Rotary (M.C.T.) Unions is offered with the machine end connection having parallel pipe threads (R.H. or L.H.) for speeds up to 1,500 r.p.m. and with an additional concentric locating spigot for speeds up to 3,000 r.p.m.

There are 3 variations of the stationary Adaptor end, diagrams on page 17 and described below:-

TYPE M.C.T./B.E.

This is a single flow unit and is suitable for transferring fluid in to, or out of rotating machines.

TYPE M.C.T./S.T.

This Rotary (M.C.T.) Union is fitted with an Adaptor suitable for double flow utilising a stationary centre tube. This gives flow areas through the centre tube and annulus. Centre tubes are only provided if ordered. The centre tube is fixed to the Rotary (M.C.T.) Union end by means of a screw thread shown as dimension 'O'. Flow can pass in through the centre tube and return through the annulus or be reversed.

TYPE M.C.T./R.S.

The Adaptor fitted to this Rotary (M.C.T.) Union is suitable for a rotating centre tube, which must be located and driven by the machine. Centre tubes are only provided if ordered. The Adaptor of this type is provided with a FILTON BALANCED MECHANICAL SEAL to seal effectively the two separate flow areas. The rotating part of this seal must be locked to the centre tube after fitting, for the seal to function correctly. Flow can pass in through the centre tube with the return through the annulus, or be reversed.

Operational Guidelines (For other conditions contact Filton Limited)

FLUIDS

Mineral oils, machine tool coolants and compressed air (lubricated). All fluids should be clean and free from abrasive particles. Special tungsten carbide seals are available for abrasive conditions, if required add "TC" as a suffix to the part number).

PRESSURE

70 bar maximum.

VACUUM

740 mm Hg. maximum (specify vacuum and we will test for this).

TEMPERATURE

-20° to 75°C.

SPEED

1500 r.p.m. maximum without a locating spigot.
3000 r.p.m. maximum with a locating spigot.

FLOW CAPACITY

Nominal Size	Type	Liquids*		Air†
		m³/h	l/min	
8 (1/4")	B.E.	0.3	5	11
	S.T. & R.S.	0.05	0.8	2
10 (3/8")	B.E.	0.8	13.3	29
	S.T. & R.S.	0.1	1.7	4
15 (1/2")	B.E.	1.7	28.3	58
	S.T. & R.S.	0.3	5	10
20 (3/4")	B.E.	2.7	45	96
	S.T. & R.S.	0.6	10	22
25 (1")	B.E.	4.1	68.3	144
	S.T. & R.S.	1.8	30	44

* Flow in cubic metres/hour at a velocity of 3 metres/second.

† Flow in cubic metres/hour free air at a velocity of 15 metres/second and a pressure of 6 bar.

IT IS NOT ADVISABLE TO COMBINE MAXIMUMS

ROTARY (M.C.T.) UNIONS



For single flow type M.C.T./B.E.

Nominal Size	Part Numbers		
	with spigot	without spigot	
8 (1/4")	16310	16260	R or L
10 (3/8")	16313	16263	R or L
15 (1/2")	16316	16266	R or L
20 (3/4")	16319	16269	R or L
25 (1")	16322	16272	R or L

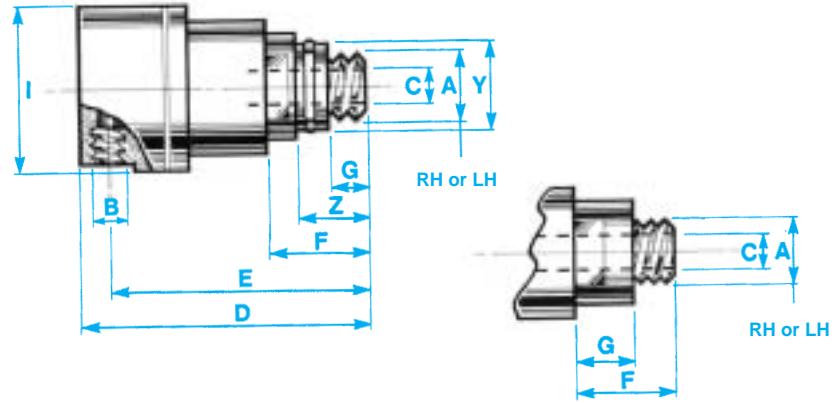

For double flow (stationary centre tube) type M.C.T./S.T.

Nominal Size	Part Numbers		
	with spigot	without spigot	
8 (1/4")	16311	16261	R or L
10 (3/8")	16314	16264	R or L
15 (1/2")	16317	16267	R or L
20 (3/4")	16320	16270	R or L
25 (1")	16323	16273	R or L

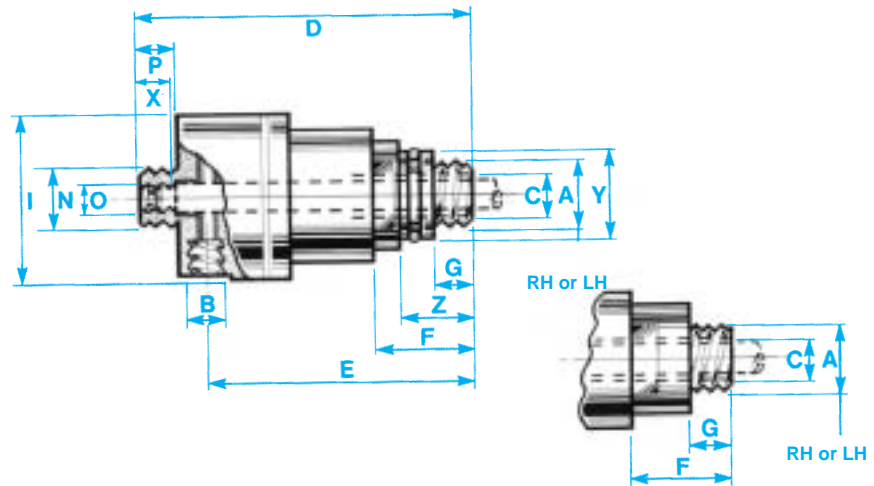

For double flow (rotary centre tube) type M.C.T./R.S.

Nominal Size	Part Numbers		
	with spigot	without spigot	
8 (1/4")	16312	16262	R or L
10 (3/8")	16315	16265	R or L
15 (1/2")	16318	16268	R or L
20 (3/4")	16321	16271	R or L
25 (1")	16324	16274	R or L

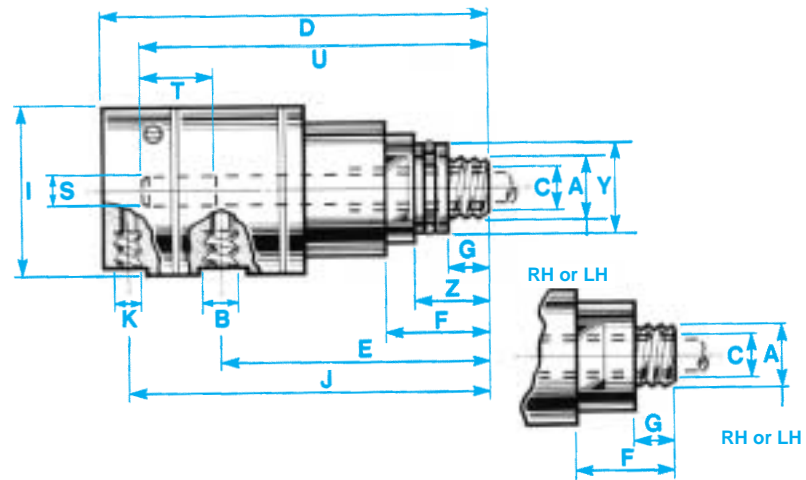

Dimensions in millimetres

Nominal Size	A		B		C	D		D		D		E		F	
	G	P	B.E.	S.T.		B.E.	S.T.	R.S.	R.S.	R.S.	*	Δ	*	Δ	*
8 (1/4")	G1/4"	11	G1/4"	G1/8"	6	137	125	141	129	188	176	120	103	37	25
10 (3/8")	G3/8"	13	G3/8"	G1/8"	10	140	128	146	134	191	179	122	106	40	28
15 (1/2")	G1/2"	16	G1/2"	G1/4"	14	168	152	171	154	230	213	143	126	45	28
20 (3/4")	G3/4"	20	G3/4"	G3/8"	18	180	155	190	165	247	222	155	130	57	31
25 (1")	G1"	22	G1"	G1/2"	22	195	180	201	186	265	250	163	148	57	42
Nominal Size	G	P	I	J		K	N	O	S	T	U		X	Y	Z
				*	Δ						*	Δ			
8 (1/4")	G1/4"	11	65	178	166	G1/8"	G1/4"	M5	4.97/4.95	60	171	159	10	15	22
10 (3/8")	G3/8"	13	65	180	168	G1/8"	G3/8"	M6	5.97/5.95	60	174	162	10	20	25
15 (1/2")	G1/2"	16	90	220	203	G1/4"	G1/2"	G1/8"	9.52/9.50	70	215	198	13	25	32
20 (3/4")	G3/4"	20	90	232	207	G3/8"	G3/4"	G1/4"	12.70/12.67	70	227	202	16	30	45
25 (1")	G1"	22	115	250	235	G1/2"	G1"	G3/8"	15.97/15.95	80	245	230	20	38	42

* With a locating spigot

Δ Without a locating spigot

† The machine recess dimension should be H7 - I.S.O. 286-2 and BS.EN 20286-2

'G' is the designation for parallel pipe threads to BS2779 and ISO 228/1

SEE PAGE 28 FOR INSTALLATION INSTRUCTIONS

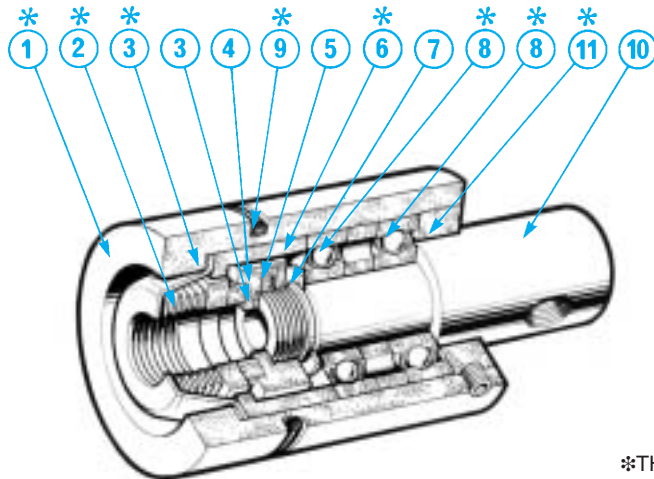

Rotary (I.N.T.) Union type B.E.

1. Body, plated steel.
2. Bellows sub-assembly, brazed stainless steel.
3. Gaskets.
4. Seal ring sub-assembly, steel/carbon.
5. Locking screw, h.t. steel.
6. Spacer.
7. Circlip, spring steel.
8. Ball bearings.
9. 'O' Ring seal, nitrile rubber.
10. Spindle, steel.
11. Locking ring, steel.

*THESE COMPONENTS ROTATE WITH THE SHAFT

The Rotary (I.N.T.) Union is for use where there is a space limitation between the roll end and the machine frame. The end of the roll is bored out to accept this self-contained unit.

The Rotary Seal fitted is a FILTON BELLOWS SEAL which is identical to the seals fitted in the Rotary (R.E.) Union, an alternative FILTON MECHANICAL SEAL is available for higher pressures and speeds.

The rotary parts of the Rotary (I.N.T.) Union are held in position by a clamping ring which is part of the roll end design. The services must be connected with flexible hose.

There are two variations of the stationary spindle end, diagrams on page 19 and described below:-

TYPE I.N.T./B.E.

This Rotary (I.N.T.) Union is a single flow unit and is suitable for transferring fluid into or out of rotating machines.

TYPE I.N.T./S.T.

This Rotary (I.N.T.) Union is fitted with a spindle suitable for double flow with a stationary centre tube. This gives flow areas through the centre tube and annulus. Centre tubes are only provided if ordered. The Centre tube is fixed to the Rotary (I.N.T.) Union by means of a screw thread shown as dimension 'O' flow can pass through the centre tube and return through the annulus or be reversed.

Operational Guidelines (For other conditions contact Filton Limited)

FLUIDS

Using a FILTON BELLOWS SEAL, water and steam.
Using a FILTON MECHANICAL SEAL, compressed air (lubricated) and oil.

All fluids should be clean and free from abrasive particles.

PRESSURE

For the FILTON BELLOWS SEAL, 17 bar maximum.
For the FILTON MECHANICAL SEAL, 34 bar maximum.

TEMPERATURE

-20° to 140°C.

SPEED

For FILTON BELLOWS SEAL 1000 r.p.m.
For FILTON MECHANICAL SEAL 1500 r.p.m.

FLOW CAPACITY

Nominal Size	Type	Water*		Steam†	Air★
		m ³ /h	l/min		
8 (1/4")	B.E.	0.3	5	11	11
	S.T.	0.05	0.8	3.4	2
10 (3/8")	B.E.	0.8	13.3	31	29
	S.T.	0.1	1.7	16	4
15 (1/2")	B.E.	1.7	28.3	61	58
	S.T.	0.3	5	27	10
20 (3/4")	B.E.	2.7	45	101	96
	S.T.	0.6	10	41	22
25 (1")	B.E.	4.1	68.3	151	144
	S.T.	1.8	30	56	44

* Flow in cubic metres/hour at a velocity of 3 metres/second.
Applies also to other liquids.

† Flow in kilograms/hour at a velocity of 30 metres/second and a pressure of 6 bar.

★ Flow in cubic metres/hour free air at a velocity of 15 metres/second and a pressure of 6 bar.

IT IS NOT ADVISABLE TO COMBINE MAXIMUMS

ROTARY (I.N.T.) UNIONS



For single flow type I.N.T./B.E.

Nominal Size	Part No.
8 (1/4")	17128
10 (3/8")	17129
15 (1/2")	17130
20 (3/4")	17131
25 (1")	17132

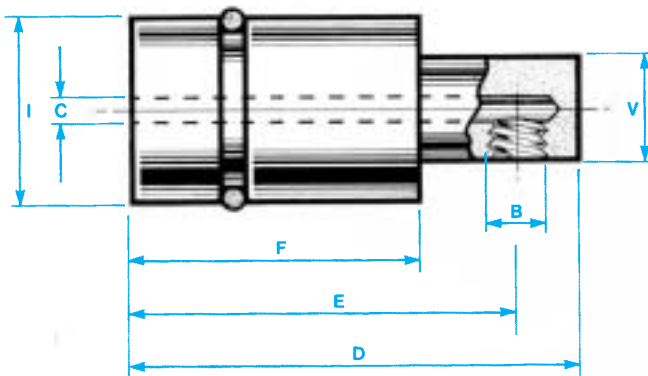

For double flow (stationary centre tube) type I.N.T./S.T.

Nominal Size	Part No.
8 (1/4")	17133
10 (3/8")	17134
15 (1/2")	17135
20 (3/4")	17136
25 (1")	17137

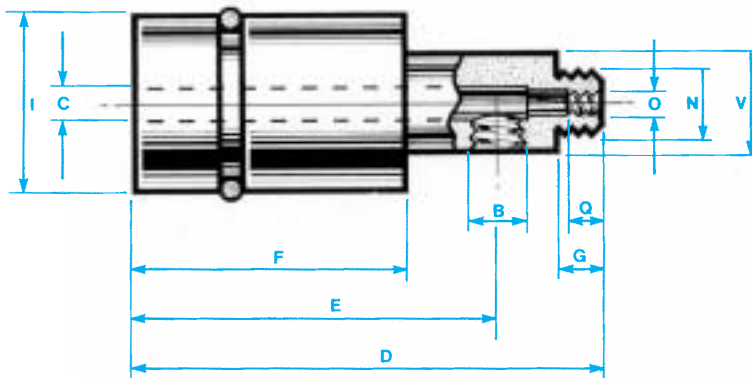

If Filton Mechanical Seal is required add suffix 'MS' to the Part Number

Dimensions in millimetres

Nominal Size	B	F	E	D B.E.	D S.T.	C	V	O	N	Q	G	I nominal
8 (1/4")	R.1/4"	66	90	104	115	6	28	M5 x 0.8	R.1/4"	10	11	44
10 (3/8")	R.3/8"	66	96	110	123	10	32	M6 x 1.0	R.3/8"	10	13	44
15 (1/2")	R.1/2"	90	115	134	150	14	40	G 1/8"	R.1/2"	13	16	73
20 (3/4")	R.3/4"	90	120	142	161	18	48	G 1/4"	R.3/4"	16	19	73
25 (1")	R.1"	96	140	170	192	22	58	G 3/8"	R.1"	19	22	83

'R' is the designation for tapered pipe threads to BS21 and ISO 7/1
'G' is the designation for parallel pipe threads to BS2779 and ISO 228/1

Roll end details

Nominal Size	d ₁	d ₂	d ₃	L ₁	L ₂	L ₃
8 (1/4")	43.94/43.81	35	30	53	12	66
10 (3/8")	43.94/43.81	35	34	53	12	66
15 (1/2")	73.15/73.10	60	42	70	19	90
20 (3/4")	73.15/73.10	60	50	70	19	90
25 (1")	82.55/82.47	70	60	70	25	96

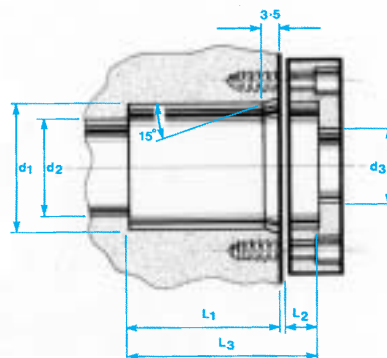

SEE PAGE 28 FOR INSTALLATION INSTRUCTIONS



SYPHON ELBOWS

The FILTON SYPHON ELBOW is a useful accessory for Rotary (P.B.), (R.E.B), (C.B.) and (C.B.N.) Unions, type S.T. on steam service.

The majority of steam cylinders are fitted with a curved syphon tube for condensate extraction, this can be seen from the typical application drawing shown on page 3.

If the diameter to length ratio of the cylinder end bore prevents the use of a curved syphon tube from being fitted the FILTON SYPHON ELBOW should be used. This allows two pieces of straight pipe to be used, the FILTON SYPHON ELBOW hinging open to allow fitting through the bore of the cylinder end.

It is advisable to fit the syphon tube to port 'O' of the Rotary Union type S.T., locking it with a backnut and checking its down pipe position in relation to port 'B' before installation.

The syphon tube assembly is cantilevered from port 'O' in the ROTARY UNION. The syphon tube length and weight can cause too much deflection and load on the ROTARY UNION bearings, it is therefore sometimes necessary to include a syphon tube support bearing within the cylinder.

The standard FILTON SYPHON ELBOWS have the bodies constructed from brass, with the hinge in stainless steel and the sealing ring in fluorocarbon. For heavy syphon tubes and corrosive conditions the bodies may be provided in stainless steel. If this is required add the code 'S' to the part number.



DURING FITTING



INSTALLED

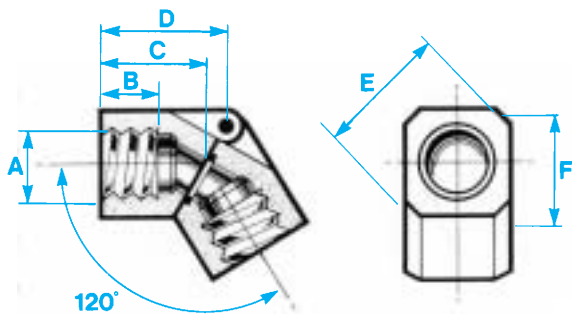

Dimensions in millimetres

Nominal Size	Part No.	A	B	C	D	E	F
8 (1/4")	14961	G 1/4"	9.5	19.0	22.2	22.9	19.1
10 (3/8")	14940	G 3/8"	12.7	27.0	31.8	29.5	22.2
15 (1/2")	14962	G 1/2"	15.8	28.6	34.1	36.3	28.6
20 (3/4")	14963	G 3/4"	19.0	34.9	42.9	42.7	34.9

'G' is the designation for parallel pipe threads to BS2779 and ISO 228/1

To select a suitable SYPHON ELBOW for a Rotary (P.B.), (R.E.), (R.E.B.) (C.B.) or (C.B.N.) Union type S.T. check the centre tube thread, dimension 'O' of the appropriate Rotary Union. The thread 'A' of the SYPHON ELBOW must match this.

Typical Application

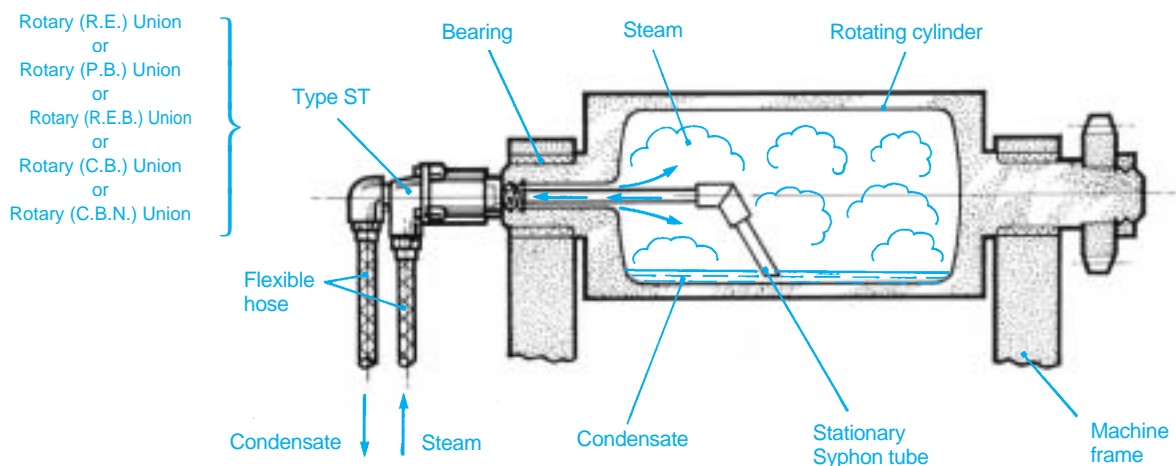

FILTON SYPHON ELBOW shown with a FILTON ROTARY UNION type S.T. on a steam heated cylinder.

The construction of our standard flexible hose is:

1. Stainless steel convoluted tube.
2. Stainless steel external reinforcing braid.
3. Mild steel end fittings.
4. The assembly is welded and pressure tested.
5. Fixed male to swivel male end fittings.

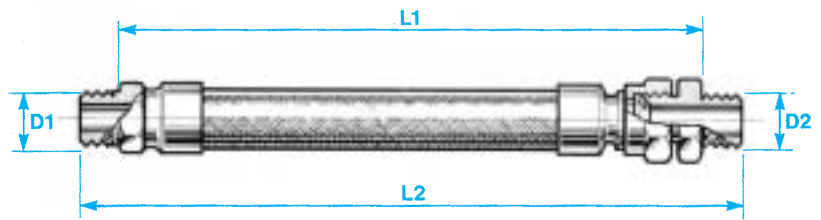

Dimensions in mm

END FITTINGS

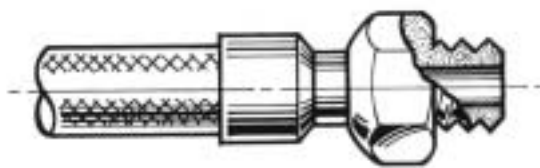

Fixed Male

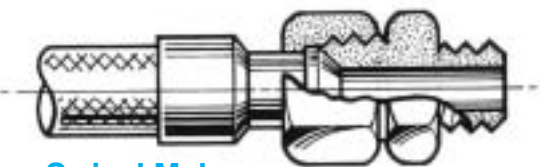

Swivel Male

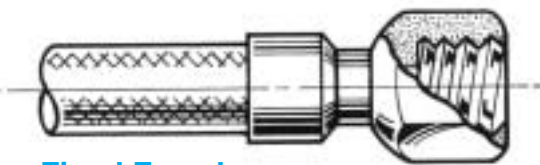

Fixed Female

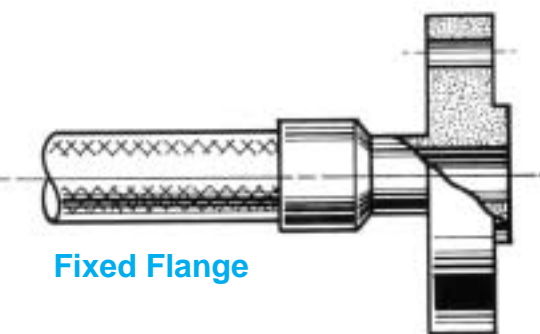

Fixed Flange

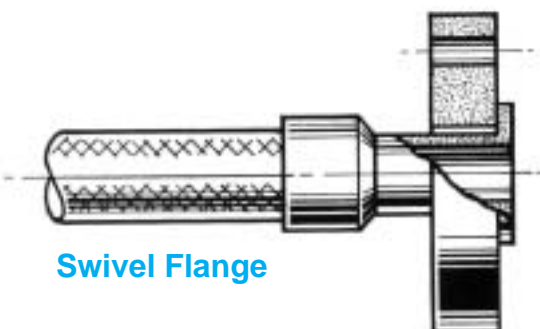

Swivel Flange

Part No.	D*	L ₁	L ₂	Min. Centre Line Bend Radius	Max Pressure bar
M240/1	R1/4"	150	182	102	85
M240/2	R3/8"	230	262	152	61
M240/3	R1/2"	305	343	203	55
M240/4	R3/4"	305	343	191	34
M240/5	R1"	380	424	261	29
M240/6	R1 1/4"	460	517	229	23
M240/7	R1 1/2"	460	517	254	21
M240/8	R2"	610	667	279	19
M240/9	R2 1/2"	610	674	330	16
M240/10	R3"	760	831	381	15
M240/11	R4"	915	1016	500	9
M240/12	R5"	915	1035	740	9
M240/13	R6"	915	1042	970	5

*'R' is the designation for tapered pipe threads to BS21 and ISO 7/1 (formerly designated B.S.P. taper)

The table and diagram above show our standard range of flexible hose for use with our Rotary Unions on water, steam, low pressure oil and hot oil services. The lengths shown are the minimum recommended to give the necessary curvature and flexibility for connection to the Rotary Unions.

We also have a similar size range to the above with the end fittings in stainless steel instead of mild steel. If these are required use the base part number M241 instead of M240.

As well as the standard range shown, we can provide lengths to your own requirements together with a variety of end fittings. The popular types of end fittings are shown in the adjacent diagrams.

Alternative pipe threads can also be provided, for example NPT.

If you require flanged fittings, one flange should be a swivel type to aid stress-free fitting. A swivel flange should always be used if the opposite end is a fixed threaded type. We can provide flanges to the following specifications:-

A.F.N.O.R.
A.N.S.I.

BS.10
BS.1560
B5.4504

D.I.N.
I.S.O.

Special Connections - Screw threads

The standard connection threads are 'G' pipes threads to BS.2779 and ISO.228/1 (formerly B.S.P. Parallel). We can supply variations on these to suit the machine requirements. The regular variations are shown below. If these are required add the Rotary Union part number.

Note - All rotary connections (dimension 'A') can be provided with RH or LH threads to suit the direction of rotation.

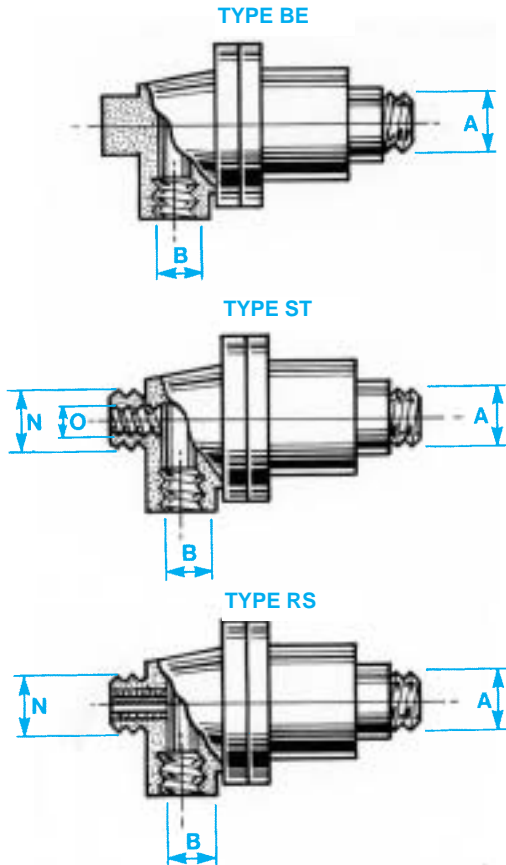

CODE	SPINDLE THREAD 'A' (RH or LH)	ADAPTOR THREADS 'B' 'N' & 'O'
F	'G' pipe thread (parallel) Female†	'G' pipe thread (parallel)
M.B.	Metric thread*	'G' pipe thread (parallel)
M.N.	Metric thread*	N.P.T.
N.P.T.	N.P.T.	'G' pipe thread (parallel)
N.P.T.2	N.P.T.	N.P.T.
N.P.T.3	'G' pipe thread (parallel)	N.P.T.
P.P.	A.P.P.T/NPSM	'G' pipe thread (parallel)
P.P.N.	A.P.P.T/NPSM	N.P.T.
T.R.	'R' pipe thread (taper)	'G' pipe thread (parallel)
T.R.2	'R' pipe thread (taper)	'R' pipe thread (taper)
U	Unified thread*	'G' pipe thread (parallel)
U.N.	Unified thread*	N.P.T.

*See table below for specific sizes.

ROTARY UNION NOMINAL SIZE	SPINDLE THREAD - 'A' (RH or LH)	
	UNIFIED (code U)	METRIC (code M)
8 (1/4")	1/2" - 20 U.N.F.	M12 x 1.25
10 (3/8")	5/8" - 18 U.N.F.	M15 x 1.50
15 (1/2")	3/4" - 16 U.N.F.	M22 x 1.50
20 (3/4")	1" - 14 U.N.S.	M30 x 1.50
25 (1")	1 1/2" - 12 U.N.F.	M35 x 1.50
32 (1 1/4")	1 3/4" - 12 U.N.	M40 x 1.50
40 (1 1/2")	2" - 12 U.N.	M50 x 1.50
50 (2")	2 1/2" - 12 U.N.	M60 x 2.00
65 (2 1/2")	3" - 12 U.N.	M76 x 2.00
80 (3")	3 1/2" - 12 U.N.	M90 x 2.00

† If an alternative female thread is required for the spindle thread 'A', add prefix 'F' to the appropriate thread code.

'G' pipe threads are to BS.2779 & ISO.228/1 (formerly B.S.P. parallel)

'R' pipe threads are to BS.21 & ISO.7/1 (formerly B.S.P. taper).

Material and Mechanical Variations

There are times when our standard materials of construction are unacceptable due to the fluid flow or the working environment.

Common Variations of this type are coded as shown adjacent. If the material you require is not shown please contact our Technical Department to discuss your requirements.

Variations on seal face materials are also available to suit specific needs.

Code	Variation
LF	Reduced torque - available for the R.E., and R.E.B. only.
LO	Overall length reduced - types B.E. only for the R.E., R.E.B., C.B. & C.B.N.
MS	Mechanical seal instead of Bellows Seal.
NI	External surfaces electroless nickel plated.
SLB	Sealed for life ball bearings - for R.E., P.B. and R.E.B. only.
SS	All metal parts (except ball bearings) in stainless steel 316S11.
SSC	Fluid wetted metal parts in stainless steel 316S11.
TC	Tungsten carbide seal faces - up to 50 (2") nominal bore only.
TCC	Tungsten carbide to carbon seal faces - up to 50 (2") nominal bore only.
Y2	Seal faces for dry running.

CONTACT OUR TECHNICAL DEPARTMENT TO DISCUSS THE APPLICATION FOR THESE VARIATIONS.

THE CODE SHOULD BE ADDED AS A SUFFIX TO THE PART NUMBER

Special Connections - flanges

If the standard screw threaded connections are unacceptable we can supply Rotary Unions with flanged interfaces. A shaft may be regularly changing from clockwise to anti-clockwise rotation which could unscrew a threaded unit. In this case the rotary spindle needs flanging.

Rotating flanges need to be carefully designed as concentric mounting is essential. These flanges can be based on any of the standard flange specifications but they will need a concentric location spigot or recess.

The common types of spindle flange design are shown in the adjacent diagram. We will manufacture rotary flanges to suit any shaft end dimensions that may be required.

If flanges are required for the stationary connections, these can be provided to any of the National or International specifications such as:

- A.F.N.O.R.
- A.N.S.I.
- BS.10
- BS.1560
- BS.4504,*
- D.I.N.
- I.S.O.

*We recommend BS.4504 for all new design work where equipment is to be used in the European Community. Flanged connections on all ports are recommended where the temperature exceeds 200°C. We have a range of flanged ROTARY (H.T.F.) UNIONS for this type of application -ask for details. If possible use the spindle flange dimensions shown below.

Spindle Flanges

Type 1

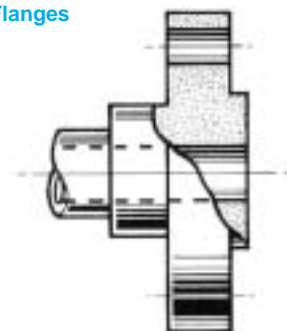

Type 2

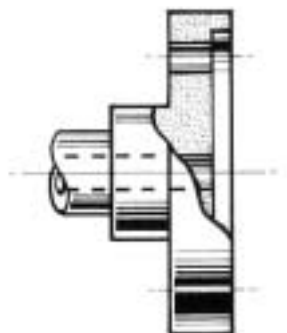

Type 3

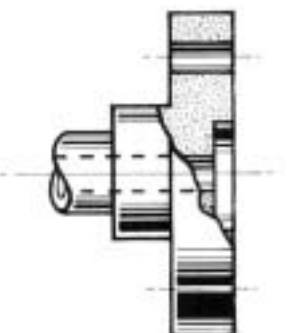

Filton Standard Spindle Flanges

It is desirable to fit a flanged spindle if rotating shafts are constantly reversing. We also recommend flanged, rather than threaded, spindles for 125 (5") and 150 (6") Rotary Unions for ease of assembly and removal. The following standard range is therefore offered. PLEASE ADD SUFFIX "SF" TO THE ROTARY UNION PART NUMBER.

'x' holes
'd' diameter

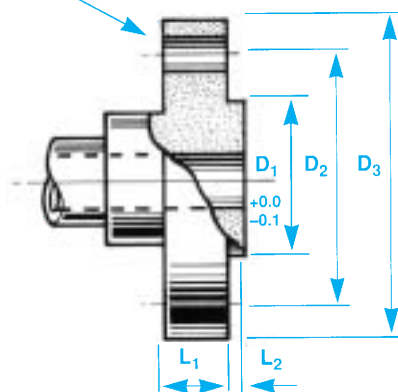

Dimensions in millimetres

ROTARY UNION NOMINAL SIZE	D ₁	D ₂	D ₃	L ₁	L ₂	x	d
15 (1/2")	45	65	95	14	6	4	14
20 (3/4")	58	75	105	16	6	4	14
25 (1")	68	85	115	16	6	4	14
32 (1 1/4")	78	100	140	18	6	4	18
40 (1 1/2")	88	110	150	18	6	4	18
50 (2")	102	125	165	20	6	4	18
65 (2 1/2")	122	145	185	20	8	4	18
80 (3")	138	160	200	20	8	8	18
100 (4")	158	180	220	22	8	8	18
125 (5")	188	210	250	22	10	8	18
150 (6")	212	240	285	22	10	8	22

BASED ON BS4504 PN16

3 PORT ROTARY UNIONS

These are manufactured on a special basis but can at times be manufactured using the basic bearing housing and main seal from any of the standard Rotary Union range shown in this technical manual.

The illustration on the right shows a typical construction using two rotating centre tubes for 3 flow channels. We use Filton Bellows Seals or Filton Mechanical Seals, dependant upon working conditions, between each flow channel.

If it is essential to prevent any "cross talk" between channels then a double seal having a bleed to atmosphere can be incorporated.

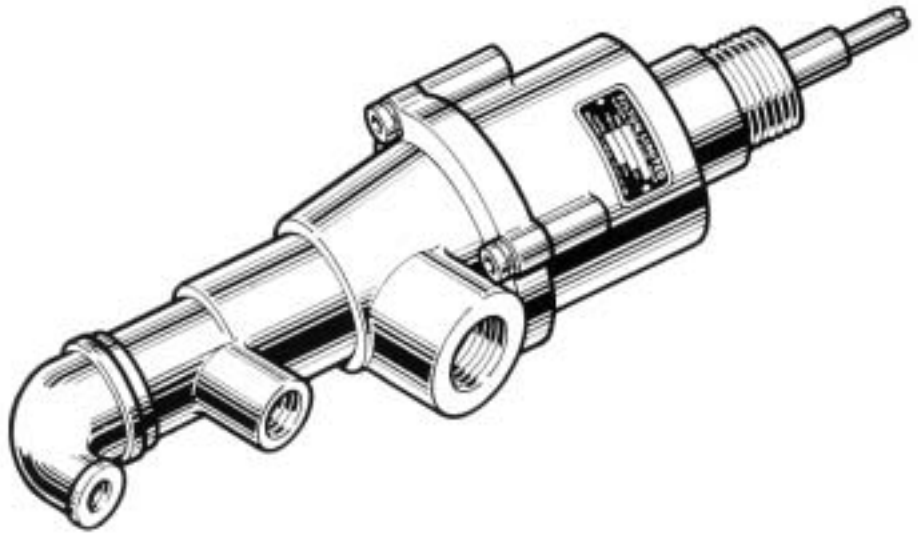

PIGGY BACK ROTARY UNIONS

At times it can be useful with multi-flow channels with different fluids if complete separation can be made.

The illustration below shows a combined unit having two channels for hydraulic oil and piggy back on the outboard end, a Rotary (P.N.) Union for a pneumatic service.

It is possible to apply this principle to more than three channels, we have designed and manufactured six channel main units with two channel Rotary Unions piggy backed, making eight channels available in total.

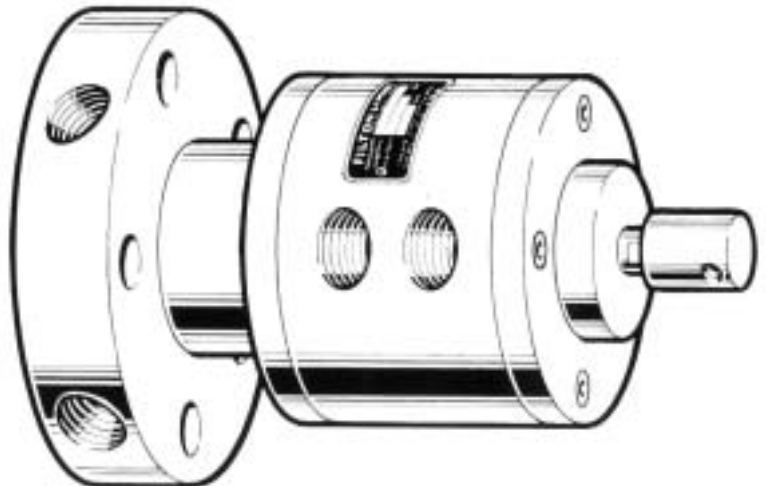
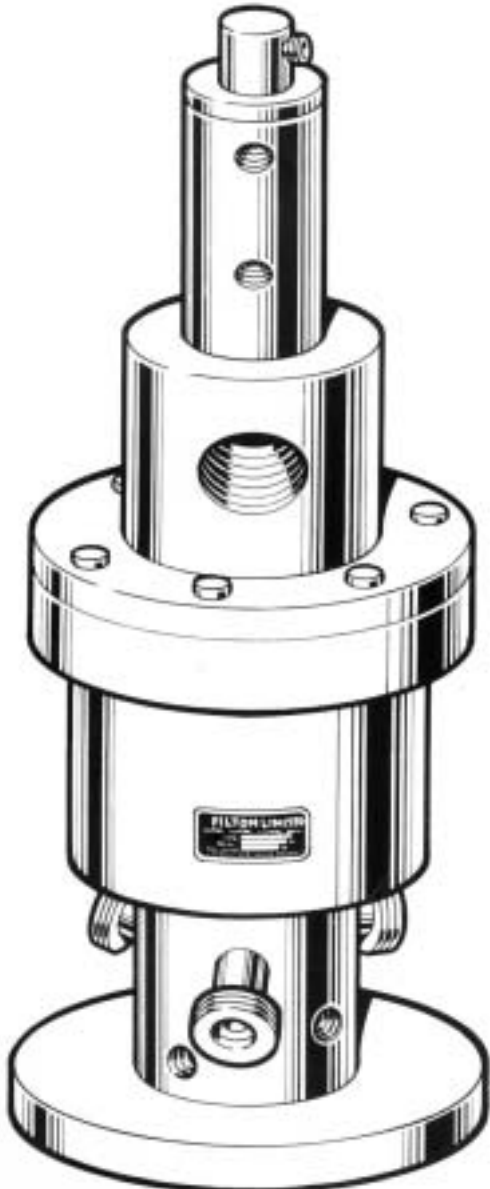

LIQUID BOTTLING/CANNING - ROTARY UNIONS

For the bottling and canning of beer, mineral water and soft drinks rotary machines are utilised which need specially designed Rotary Unions.

Multi-channel systems are generally used with facilities for compressed air, carbon dioxide, nitrogen and C.I.P. (cleaning in place) systems.

The illustration on the left is a typical example having connections for C.I.P. compressed air, carbon dioxide and on the top an electrical slip ring system for instrumentation and control.

We can provide connections for any of the standard C.I.P. systems including RJT, ISS, DIN or TRICLOVER.

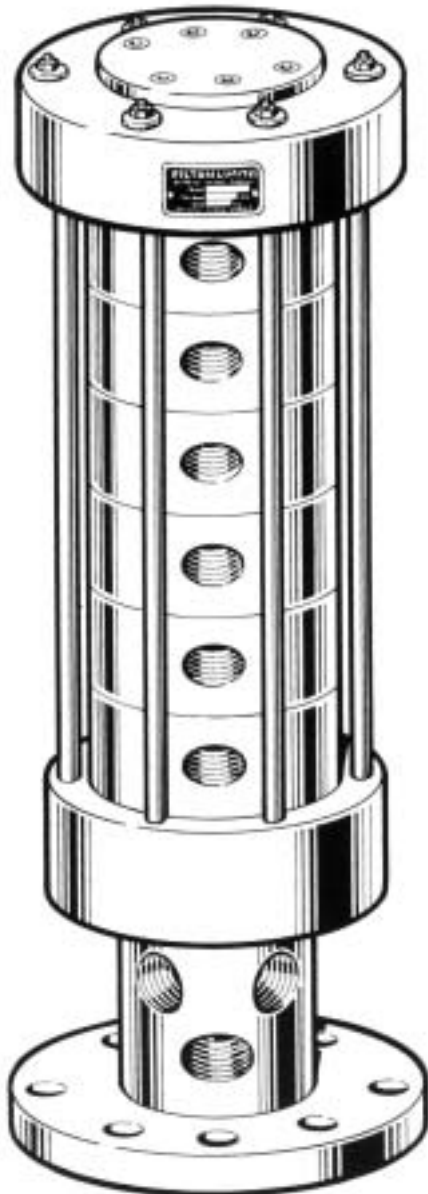

MULTI PORT ROTARY UNIONS

Although, in the main, the applications for Rotary Unions are covered by our standard range, there are many times when the machinery specification is impossible to satisfy without resorting to a special multi-channel design.

The illustration on the left shows a typical construction of a six channel unit built on a sectioned body basis with a tie bar system. Solid body designs are also used dependant on the working specification.

We have had many years experience in designing and manufacturing Multi Port Rotary Unions in a wide range of materials of construction including aluminium, bronze, carbon steel, stainless steel and nickel alloys.

The Multi Port Rotary Unions we have provided have included services for cooling, heating, hydraulics, pneumatics and vacuum.

There are times when there is a requirement for the rotary transfer of electrical services as well as the services indicated in the previous paragraph. We can design in this facility if required whether it be for power slip rings and brushes or for instrumentation purposes.

OVERSHAFT ROTARY UNIONS

All of the standard Rotary Unions in this technical manual are for connecting to the end of a rotating shaft. There are times when end access is impossible and the only way to transfer services is at some point along the shaft.

The illustration on the right is a typical design for an Overshaft Rotary Union. The type shown is for two services passing into and axially along the machine shaft.

We can also provide a design which incorporates the rotary connection into the Rotary Union sleeve for transferring services externally along the shaft.

We recommend that every effort should be made to obtain shaft end access to use standard designs as Overshaft Rotary Unions are costly and can require major machinery dismantling for servicing purposes.

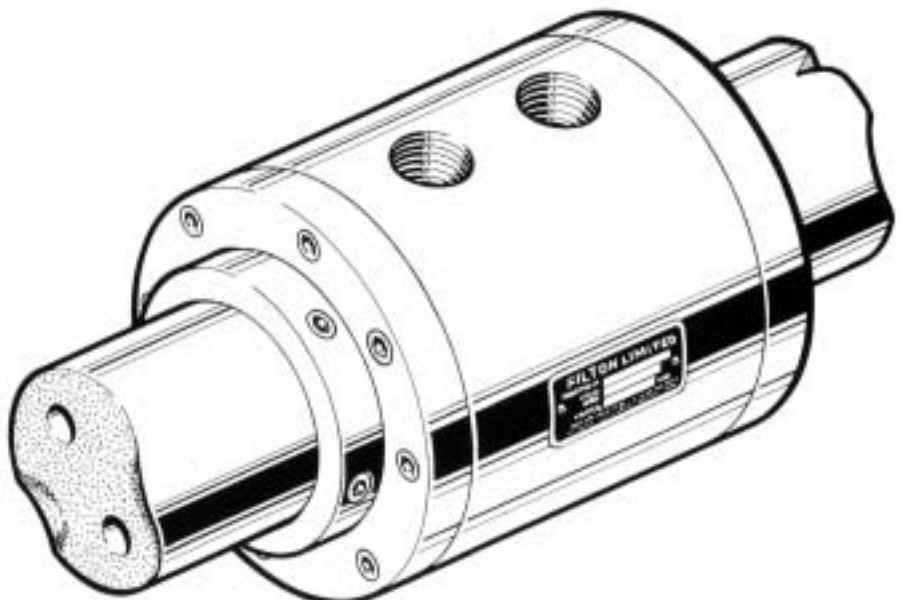

OBSOLETE No:	REPLACEMENT No:	SIZE & TYPE	SEE PAGE	OBSOLETE No:	REPLACEMENT No:	SIZE & TYPE	SEE PAGE
14385	15472	50 (2") C.B.N./S.T.	12	14638	17197	10 (3/8") R.E./R.S.	4
14397	16660	20 (3/4") R.E./R.S.	4	14641	17216	10 (3/8") C.B./R.S.	10
14398	16664	32 (1 1/4") R.E./R.S.	4	14644	17196	8 (1/4") R.E./R.S.	4
14486	15473	50 (2") C.B.N./R.S.	12	14647	17215	8 (1/4") C.B./R.S.	10
14502	16661	25 (1") R.E./R.S.	4	15185	18070	8 (1/4") L.C./B.E.	14
14541	16663	32 (1 1/4") R.E./R.S.	4	15186	18073	15 (1/2") L.C./B.E.	14
14543	16659	20 (3/4") R.E./R.S.	4	15187	18074	20 (3/4") L.C./B.E.	14
14544	16662	25 (1") C.B./R.S.	10	15188	18075	25 (1") L.C./B.E.	14
14547	15471	50 (2") C.B.N./B.E.	12	15441	17350	50 (2") R.E.B./B.E.	8
14551	17238	50 (2") R.E.B./S.T.	8	15442	17238	50 (2") R.E.B./S.T.	8
14552	17350	50 (2") R.E.B./B.E.	8	15443	17351	20 (2") R.E.B./R.S.	8
14553	17351	50 (2") R.E.B./R.S.	8	15444	18131	65 (2 1/2") R.E.B./B.E.	8
14555	16658	15 (1/2") C.B./R.S.	10	15445	18132	65 (2 1/2") R.E.B./S.T.	8
14556	16657	15 (1/2") R.E./R.S.	4	15446	18133	65 (2 1/2") R.E.B./R.S.	8
14562	18105	40 (1 1/2") R.E.B./S.T.	8	15447	17265	80 (3") R.E.B./B.E.	8
14563	18104	40 (1 1/2") R.E.B./B.E.	8	15448	17266	80 (3") R.E.B./S.T.	8
14564	18106	40 (1 1/2") R.E.B./R.S.	8	15449	17263	80 (3") R.E.B./R.S.	8
14565	18102	40 (1 1/2") C.B.N./S.T.	12	15474	18240	65 (2 1/2") C.B.N./B.E.	12
14566	18101	40 (1 1/2") C.B.N./B.E.	12	15475	18241	65 (2 1/2") C.B.N./S.T.	12
14567	18103	40 (1 1/2") C.B.N./R.S.	12	15476	18242	65 (2 1/2") C.B.N./R.S.	12
14624	17265	80 (3") R.E.B./B.E.	8	16667	18106	40 (1 1/2") R.E.B./R.S.	8
14625	17266	80 (3") R.E.B./S.T.	8	16668	18103	40 (1 1/2") C.B.N./R.S.	12
14626	17263	80 (3") R.E.B./R.S.	8	16675	17351	50 (2") R.E.B./R.S.	8
14627	15477	80 (3") C.B.N./B.E.	12	16676	15473	50 (2") C.B.N./R.S.	12
14628	15478	80 (3") C.B.N./S.T.	12	16677	18133	65 (2 1/2") R.E.B./R.S.	8
14629	15479	80 (3") C.B.N./R.S.	12	16678	18242	65 (2 1/2") C.B.N./R.S.	12
14630	18131	65 (2 1/2") R.E.B./B.E.	8	16679	17263	80 (3") R.E.B./R.S.	8
14631	18132	65 (2 1/2") R.E.B./S.T.	8	16680	15479	80 (3") C.B.N./R.S.	12
14632	18133	65 (2 1/2") R.E.B./R.S.	8	17352	18131	65 (2 1/2") R.E.B./B.E.	8
14633	18240	65 (2 1/2") C.B.N./B.E.	12	17353	18132	65 (2 1/2") R.E.B./S.T.	8
14634	18241	65 (2 1/2") C.B.N./S.T.	12	17354	18133	65 (2 1/2") R.E.B./R.S.	8
14635	18242	65 (2 1/2") C.B.N./R.S.	12				

HEALTH AND SAFETY

The Rotary Unions shown in this leaflet should not present any hazard when correctly fitted and used.

To ensure satisfactory performance, every Rotary Union is run-in and leakage tested before despatch.

It is essential to use the correct hand of rotary connection thread to ensure the Rotary Union will not unscrew (see the Installation Instructions) page 28.) If a shaft reverses rotation then it must be locked or preferably use a flanged connection.

At some time the seals in the Rotary Union will leak, so inspect daily, also ensure that leakages are not hazardous to personnel and that the Rotary Union is removed for repair immediately. If leakages are not attended to promptly, bearing seizure may occur causing flexible hose failure and massive leakage. Fit protective guards if leakages or the rotating spindle are likely to be hazardous to personnel or equipment.

For hazardous applications fit an excess torque detector to stop the machine before major damage occurs to flexible hoses causing massive leakage.

With oil systems minor leakages occur due to the natural characteristics of oil preventing seal faces from contacting fully.

Please note that non-asbestos gaskets have replaced the compressed asbestos fibre material used previously.

MAINTENANCE OF ROTARY UNIONS



ROTARY (R.E.), (P.B.) AND (R.E.B.) UNIONS

The Filton Bellows Seal fitted to the Rotary (R.E.B.) Union is self-adjusting within its working life. The ball bearings fitted need occasional greasing. Generally once per shift on 'hot' applications and once per month on 'cold' applications is suitable. For specific recommendation we suggest you contact your grease manufacturer.

Before despatch we lubricate the bearings with a bentone base grease, ensure your lubricant is compatible with this.

RECOMMENDED LUBRICANTS

<u>BARDAHL</u> Multipurpose Grease No 2 HauteTemperature	-20°/+160°C -10°/+180°C	<u>DOW CORNING</u> Molykote 44M	-40°/+180°C	<u>MOBIL</u> Mobilplex 47 Mobiltemp 1	-25°/+150°C +10°/+180°C
<u>BP</u> Energrease LS2 Energrease HTG2	-30°/+130°C -20°/+180°C	<u>ELF OIL</u> Multi 2 Caloris (Extemp 2)	-25°/+130°C -10°/+180°C	<u>ROCOL</u> Sapphire 2 Sapphire Hi-Temp 2	-30°/+150°C -40°/+180°C
<u>BURMAH-CASTROL</u> Spheerol MP3 Spheerol B2	-20°/+110°C -25°/+180°C	<u>ESSO</u> Beacon 2 IL 2880	-25°/+125°C -20°/+180°C	<u>SHELL</u> Alvania EP LF2 Darina Grease R2	-20°/+120°C +10°/+190°C
<u>CALTEX</u> Regal Starfak Premium 2 Thermax EP	-40°/+120°C -20°/+180°C	<u>KLÜBER</u> Centoplex 2EP Petamo GHY443	-20°/+130°C -25°/+180°C	<u>TEXACO</u> Multifak AFB2 Starfak Ultratemp 2	-40°/+120°C -40°/+175°C

NOTE: FOR SUB-ZERO TEMPERATURES check with our Technical Department that the Rotary Union you are considering is acceptable for the temperature and fluid.

ROTARY (C.B.) and (C.B.N.) UNIONS

The Bellows Seal fitted to the Rotary (C.B.N.) Union is self adjusting within its working life. The Rotary (C.B.N.) Union has dry carbon journal and thrust bearings operating on hardened surfaces. DO NOT GREASE. We advise periodic inspection for bearing wear and leakage.

ROTARY (M.C.T.) UNIONS

The FILTON MECHANICAL SEAL fitted to the Rotary (M.C.T.) Union is self adjusting within its working life. The pre-loaded angular contact ball bearings fitted are pre-packed with a special grease which has long life and low internal friction keeping the temperature lower than conventional bearing greases at high speeds. Re-lubrication need only be carried out during overhaul periods.

RECOMMENDED LUBRICANT:

Kluber isoflex NBU15

ROTARY (I.N.T.) UNIONS

The FILTON BELLOWS SEAL or MECHANICAL SEAL fitted to the Rotary (I.N.T.) Union is self adjusting within its working life. The bearings are pre-packed with a suitable grease. Replace seals and bearings when leakage occurs.

RECOMMENDED LUBRICANT:

Kluber TK.44N.

ROTARY (L.C.) UNIONS

The mechanical seal fitted to this range is self adjusting and the ball bearings are the life lubricated type.

ROTARY (P.N.) UNIONS

The mechanical seal fitted to this range is self adjusting but does require periodic lubrication with a light mineral oil. The ball bearings are the life lubricated type.

NOTES:

In all cases when leakage occurs, remove the Rotary Union and change the seals and bearings. Separate installation and maintenance information is available.

REPAIR SERVICES ARE AVAILABLE IN OUR FACTORY

ROTARY UNION INSTALLATION

FILTON

Install as shown in the diagrams adjacent. Ensure that spindle thread 'A' is RH or LH to suit the direction of rotation of the machine shaft as shown.

If the machine shaft reverses direction of rotation securely lock the spindle or preferably use a flanged connection (see page 23).

Fully detailed Installation and Maintenance leaflets are available.

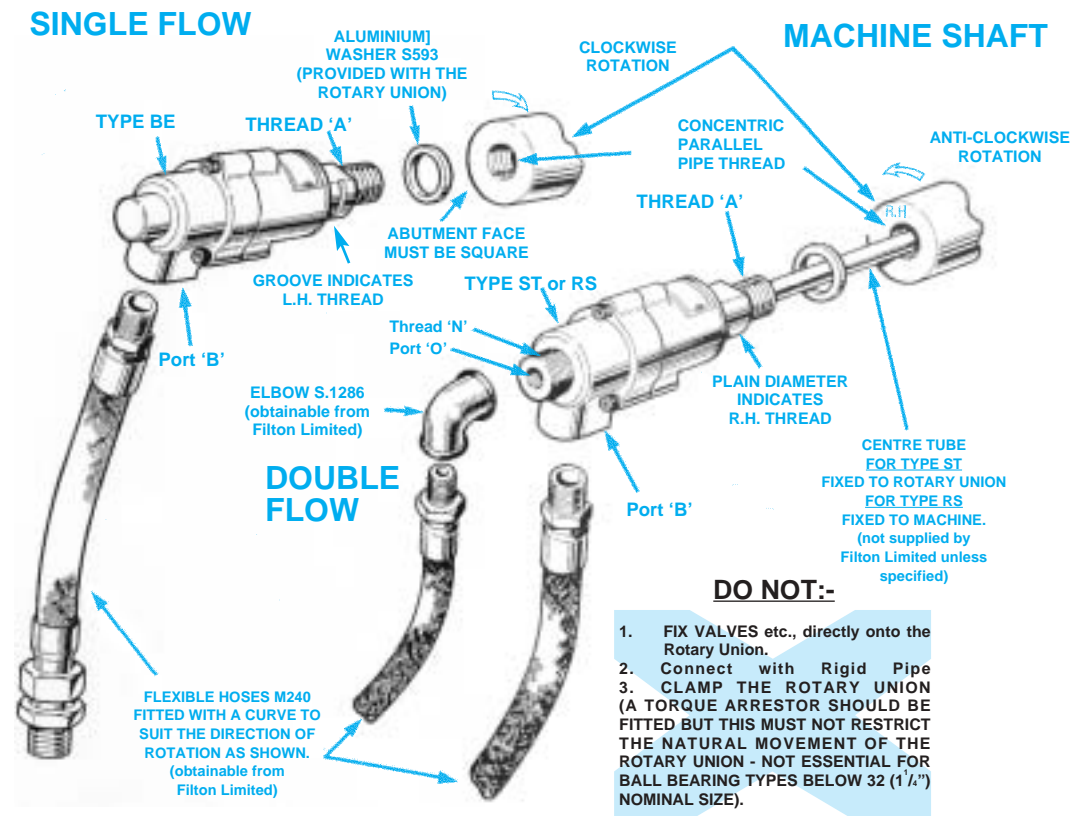

CONNECTIONS FOR ROTARY (R.E.) (P.B.) (R.E.B.) (C.B.) (C.B.N.) AND (I.N.T.) UNIONS

FLEXIBLE HOSES			ELBOWS		HEX BUSHES	
Part No	Thread	Length	Part No	Threads	Part No	Threads
M240/1	R $\frac{1}{4}$ "	150	S.1286/1	Rp $\frac{1}{4}$ " x $\frac{1}{4}$ "	S.1287/1	R $\frac{3}{8}$ " x Rp $\frac{1}{4}$ "
M240/2	R $\frac{3}{8}$ "	229	S.1286/2	Rp $\frac{3}{8}$ " x $\frac{1}{4}$ "	S.1287/2	R $\frac{1}{2}$ " x Rp $\frac{1}{4}$ "
M240/3	R $\frac{1}{2}$ "	305	S.1286/4	Rp $\frac{1}{2}$ " x $\frac{1}{4}$ "	S.1287/4	R $\frac{3}{4}$ " x Rp $\frac{1}{4}$ "
M240/4	R $\frac{3}{4}$ "	305	S.1286/7	Rp $\frac{3}{4}$ " x $\frac{1}{4}$ "	S.1287/8	R1" x Rp $\frac{3}{8}$ "
M240/5	R1"	380	S.1286/10	Rp1" x $\frac{3}{8}$ "	S.1287/13	R1 $\frac{1}{4}$ " x Rp $\frac{1}{2}$ "
M240/6	R1 $\frac{1}{4}$ "	460	S.1286/14	Rp1 $\frac{1}{4}$ " x $\frac{1}{2}$ "	S.1287/19	R1 $\frac{1}{2}$ " x Rp $\frac{3}{4}$ "
M240/7	R1 $\frac{1}{2}$ "	460	S.1286/18	Rp1 $\frac{1}{2}$ " x $\frac{3}{4}$ "	S.1287/25	R2" x Rp1"
M240/8	R2"	610	S.1286/23	Rp2" x 1"	S.1287/31	R2 $\frac{1}{2}$ " x Rp1 $\frac{1}{4}$ "
M240/9	R2 $\frac{1}{2}$ "	610	S.1286/27	Rp2 $\frac{1}{2}$ " x $\frac{1}{4}$ "	S.1287/38	R3" x Rp1 $\frac{1}{2}$ "
M240/10	R3"	760	S.1286/29	Rp3" x $\frac{1}{2}$ "	S.1287/44	R4" x Rp2"
M240/11	R4"	915	S.1286/33	Rp4" x 2"	S.1287/45	R4" x Rp2 $\frac{1}{2}$ "
M240/12	R5"	915	S.1286/34	Rp4" x 2 $\frac{1}{2}$ "	S.1287/47	R5" x Rp3"
M240/13	R6"	915	S.1286/37	Rp5" x 3"	S.1287/50	R6" x Rp4"
			S.1286/39	Rp6" x 4"		

Stainless/mild steel construction.
For full details of hoses see page 21.

Malleable iron for pressures up to 17 bar.

NOTE: Pipe thread R is taper male to BS21 + ISO R7/1

Pipe thread Rp is parallel female to BS21 + ISO R7/1 to suit R taper male.

CONNECTIONS FOR ROTARY (M.C.T.) UNIONS - Use industry standard-hydraulic hose and fittings.

CONNECTIONS FOR ROTARY (L.C.) & (P.N.) UNIONS - Use industry standard-pneumatic hose and fittings.

HOW TO SELECT SUITABLE FITTINGS:

For single flow (type B.E.) - use a flexible hose to match port 'B'.

For double flow (type S.T. or R.S.) for steam - use flexible hoses to match ports 'B' + 'O' and a reducing elbow of similar size.

For double flow (type S.T. or R.S.) for other fluids - use 2 flexible hoses to match port 'O', a hex bush to match 'B' + 'O' and an elbow to match 'N' and 'O'.

e.g. For a 40 (1 $\frac{1}{2}$ ") R.E.B./S.T. 18105 (page 9) 'B' = G1 $\frac{1}{2}$ ", use flexible hose M240/7 and 'O' = G $\frac{3}{4}$ " use flexible hose M240/4 with 1 $\frac{1}{2}$ " x $\frac{3}{4}$ " elbow S1286/18.

e.g. For a 40 (1 $\frac{1}{2}$ ") R.E.B./R.S.18106 (page 9) 'O' = $\frac{3}{4}$ " use 2 hoses M240/4, elbow 1 $\frac{1}{2}$ " x $\frac{3}{4}$ " S1286/18 for 'N' and hex bush 1 $\frac{1}{2}$ " x $\frac{3}{4}$ " S1287/19 for port 'B'.

INDEX

Bearings	2	Repair	27	Rotary (R.E.) Unions	4
Bellows seals	2	Rotary (C.B.) Unions	10	Rotary (R.E.B.) Unions	8
Cross reference table (obsolete units)	26	Rotary (C.B.N.) Unions	12	Safety and Health	26
Flexible hose	21	Rotary (I.N.T.) Unions	18	Seals, bellows and mechanical	2
Health & Safety	26	Rotary (L.C.) Unions	14	Semi-standards	22
Installation	28	Rotary (M.C.T.) Unions	16	Specials	24
Maintenance	27	Rotary (P.B.) Unions	6	Syphon Elbows	20
Mechanical seals	2	Rotary (P.N.) Unions	15	Typical applications	3

Throughout this technical manual the designation for pipe threads is:

'G' - Parallel pipe thread to BS.2779 and ISO.228/1 (formerly designated B.S.P. - Parallel)

'R' - Tapered pipe thread to BS.21 and ISO.7/1 (formerly designated B.S.P. - Taper)

APPLICATION LIST

Page	Model	Size Range ¹	Air	Gas ³	Oil Lubricating	Oil Hydraulic	Oil Heat transfer	Steam	Vacuum	Water
4	R.E.	8 (1/4") to 32 (1 1/4")	✓ ²	✓	✓		✓	✓	✓	✓
6	P.B.	15 (1/2") to 25 (1")	✓ ²	✓	✓				✓	✓
8	R.E.B.	40 (1 1/2") to 150 (6") ⁵	✓ ²	✓	✓		✓	✓	✓	✓
10	C.B.	8 (1/4") to 32 (1 1/4")					✓ ⁴	✓		✓
12	C.B.N.	40 (1 1/2") to 150 (6") ⁵					✓ ⁴	✓		✓
14	L.C.	8 (1/4") to 20 (3/4")	✓ ²		✓					✓
15	P.N.	8 (1/4") to 20 (3/4")	✓						✓	
16	M.C.T.	8 (1/4") to 25 (1")	✓ ²	✓	✓	✓			✓	
18	I.N.T.	8 (1/4") to 25 (1")	✓ ²		✓	✓			✓	✓

Notes

- ✓ = Suitable but check full working conditions
- ¹ = The size stated is the rotary spindle end connection (dimension "A" in all the outline drawings)
- ² = For lubricated air only. If air is dry and the P.N. is unsuitable, we can provide special seals for other models
- ³ = Dependant on the type of gas and working conditions - refer to our Technical Department
- ⁴ = Flanges may be required dependant on working temperature
- ⁵ = Flanges can simplify fitting and assist removal for maintenance on sizes 100 (4") and larger

TO SELECT THE MODEL:

1. Check the fluid column
2. Match with the size range
3. Turn to the appropriate page for the model indicated to check the full working conditions and any limitations
4. If more than one model is indicated, examine the application information on the appropriate pages

NEED ADVICE?

Please telephone our Technical Department on (01926) 423191. The following information will be needed:

1. Fluid; 2. Fluid flow rate; 3. Fluid pressure; 4. Fluid temperature; 5. Ambient temperature; 6. Rotational speed; 7. Direction of rotation; 8. Working cycle; 9. Any usual features, e.g. installed outside, open to weather.



MECHANICAL SEALS

Our range of ROLTAC® Mechanical Seals include balanced internally mounted seals to DIN 24960 for shaft diameters ranging from 25 to 100mm diameter. We also have a range of externally mounted seals for shaft diameters from 19 to 75mm diameter.

Both internally and externally mounted seals are also available for imperial sized shafts.

AIR BREATHER FILTERS

This product is a device which equalises pressure and prevents the ingress of abrasives to closed chambers such as gear boxes and hydraulic power packs. The standard range covers from R¹/₈" to R¹/₄" with options of four grades of filter element, from 5 to 65 micrometres particle retention size.



SWIVEL JOINTS

These are rotary seals for slow or indexing rotation rather than continuous rotation where Rotary Unions are used. We have a standard range of single flow Swivel Joints for G¹/₄" to G3" nominal size and a double flow range from G¹/₄" to G³/₄". The pressure range of standards is from 85 to 400 bar.

We design and manufacture specials including multi-port types including, when needed, electrical slip ring systems.

The largest Swivel Joint we have designed and manufactured, so far, weighed 1.25 tonne.



SPECIALIST SEALS

We will consider any rotary shaft sealing application which cannot be resolved with any of our standard seals. We have gained a wide experience, with our bespoke service, which has given us a considerable data bank to draw on to resolve the more unusual applications.